

# Request for Proposals

PORT OF ALSEA

## BOAT LAUNCH AND MARINA CONSTRUCTION PROJECT

RFP # 2018-01

---

DESIGN/BUILD CONTRACTOR  
With a Guaranteed Maximum Price

For

CONSTRUCTION

Of the

BOAT LAUNCH AND MARINA CONSTRUCTION PROJECT

---

TO: Prospective Design/Build Proposers

SUBJECT: Request for Proposals  
Boat Launch and Marina Construction Project

ISSUE DATE: August 10, 2018

ISSUED BY: Port of Alsea, Oregon

RFP CONTACT: Roxie Cuellar / Port Manager  
Port of Alsea  
365 Port Street  
Waldport, Oregon 97394  
Phone: (541) 563-3872

Email: [rcuellar@portofalsea.com](mailto:rcuellar@portofalsea.com)

PROPOSALS DUE: September 20, 2018 2:00 p.m.

DESIGN/BUILD CONTRACTOR  
With a Guaranteed Maximum Price Request for Proposals

PORT OF ALSEA, OREGON

Boat Launch and Marina  
Construction Project

TABLE OF CONTENTS

I.	Introduction	Pages 3-5
	A. Request for Proposals Advertisement	
	B. Project Overview	
II.	Selection Process	Pages 5-7
	A. Selection Overview	
	B. Schedule for Selection	
III.	Services to be Provided	Pages 7-8
	A. Description of Services	
	B. Sample Contract and Negotiations	
IV.	Proposal Requirements	Pages 8 -14
	A. Submittal Requirements	
	B. Detailed Proposal Requirements	
	C. Public Information	
	D. Interview Information	
	E. Evaluation Criteria	
	F. Final Selection	
V.	Protests and Requests for Change	Page 14
	A. Solicitation Protests and Requests	
	B. Selection Questions and Protests	

Attachment A - Proposal Certification Statement Form

Attachment B - Design/Build Criteria Scope of Work

Attachment C - Sample Design/Build Agreement - including:

Exhibit 1 - State of Oregon General Conditions for Public Improvement Contracts

Exhibit 2 - GMP Amendment

Attachment D - BOLI Prevailing Wage Rates for Public Works Contracts in Oregon

Attachment F - Categories of General Conditions Work

## INTRODUCTION

### A. REQUEST FOR PROPOSALS ADVERTISEMENT — This is a copy of the advertisement posted in the Daily Journal of Commerce.

**RFP #2018-01**

DESIGN/BUILD CONTRACTOR  
With a Guaranteed Maximum Price for the Construction of  
Boat Launch &  
Marina Improvements

Date of Issue: August 10, 2018

Mandatory Pre-Proposal Conference: September 5, 2018, 11:00 a.m.

Closing Time and Date: September 20, 2018 2:00 p.m.

### PUBLISHED NOTICE

The Port of Alsea (the Port), requests Proposals from experienced Design/Build Contractors for the design and construction of the " Boat Launch and Marina Construction Project" (the `Project"). The Port intends to enter into a contract with the selected Design/Build Contractor (DBC) for Program Refinement and Schematic Design services based on a not to exceed price. At the completion of the Schematic Design phase, the Design/Build Contractor will submit a Guaranteed Maximum Price (GMP) proposal, and if acceptable, the Port and the DBC will execute a GMP Amendment covering the remaining scope of the of the design and construction services. The DBC firms responding to this RFP will be evaluated based upon qualifications, prior experience, proposed approach (including schedule and plan for completing the work), schematic design fee, and any other evaluation criteria identified in this procurement.

The Project is generally described as but is not limited to the following in-water work:

- Replacement of existing boat launch, which involves removing and disposing the existing concrete ramp, abutment, wooden boarding float and steel piling; and installation of a new concrete ramp, abutment, boarding float, and piling. The boat ramp will be designed and engineered by the Oregon State Marine Board.
- Design and construction of a new marina, which will include, at a minimum, removing and replacing support piles, existing gangways and docks, and installation on new piling, docks, and fingers. The marina must include a minimum of 40 slips and 12 side ties.

Copies of the Request for Proposal document can be obtained from:

Roxie Cuellar / Port Manager  
Port of Alsea  
365 Port Street  
Waldport, Oregon 97394  
Phone: (541) 563-3872  
Email: [rcuellar@portofalsea.com](mailto:rcuellar@portofalsea.com)

If, after receiving the packet you have inquiries, please contact Roxie Cuellar, Port Manager.

Proposals are due September 20, 2018 2:00 p.m. Proposals received after the specified time will not be considered.

**MANDATORY PRE-PROPOSAL CONFERENCE:** A mandatory pre-proposal conference will be held at September 5, 2018, 11:00 a.m. at the Port of Alsea, at 365 Port Street, Waldport, Oregon. A representative of each Proposer's firm is required to attend. The pre-proposal conference will be the Proposers' main opportunity to discuss the Project with the Port and the Project Manager.

**IT IS MANDATORY THAT THE POTENTIAL PROPOSERS ATTEND THIS PRE-PROPOSAL CONFERENCE. PROPOSALS WILL NOT BE ACCEPTED FROM PROPOSERS WHO DO NOT ATTEND.**

**INTERVIEWS:** The Port intends to interview one or more of the top finalists. Interviews are tentatively scheduled for October 4, 2018 at the Port Office, at 365 Port Street, Waldport, Oregon.

All Proposers must be registered with the Oregon Construction Contractors Board prior to submitting Proposals. Failure to register will be sufficient cause to reject Proposals as non-responsive. For this Project, the provisions of ORS 279.348 through 279.380, relative to prevailing wage rates apply. The Contractor and all subcontractors shall comply with prevailing wage rate requirements.

This solicitation does not obligate the Port of Alsea to pay any costs incurred in preparation of Proposals or presentations. The Port reserves the right to reject any Proposal not in compliance with all prescribed requirements and the Port may reject for good cause any or all Proposals upon a written finding that it is in the public interest to do so.

## **BACKGROUND**

The Port of Alsea provides easy access to the Alsea river and bay, one of Oregon's most pristine estuaries with excellent opportunities for recreation. The Port of Alsea facilities include a boat launch, boat moorage, and a picnic area. The Port of Alsea is an important economic driver for the communities of Seal Rock, Waldport, and Yachats.

Time and weather have taken their toll on the 35 year old boat launch and marina, and they are in need of immediate replacement. In addition, use of the current facilities exceeds maximum capacity during the busy season and thus the launch and marina need to be expanded. Voters in the Port of Alsea District passed Measure 21-182 in 2018, which provides bond revenue to fund these Capital Improvements and revitalize the Port. In addition, the Port of Alsea received a grant from the Oregon State Marine Board to cover a portion of the cost of constructing the new boat ramp. The total budget for this project is approximately \$2,500,000.

## **B. PROJECT OVERVIEW**

The project can be described as the (a) removal of the existing boat launch, (b) construction of a new boat launch which will be designed and engineered by the Oregon State Marine Board, (c) removal of the existing marina, and (d) the design, engineering, and construction of a new marina facility with at least 40 slips and 12 side ties.

## **DESIGN TEAM**

The DBC will be responsible for assembling, and contracting with the professional design team and coordinating all design and construction activities necessary to deliver the Boat Launch and Marina Improvements as previously described.

## **II. SELECTION PROCESS**

### **A. SELECTION OVERVIEW**

The Port is seeking a qualified DBC firm for the services identified herein related to the construction of the Boat Launch and Marina Improvements. In accordance with Oregon Administrative Rules 125-310-0220 and 137-040-0570, the Port will use the Request for Proposal (RFP) competitive procurement process to select and enter into a contract with the DBC. In accordance with those rules and ORS 279.015, the Port has obtained an exemption from applicable competitive bidding requirements.

The Port has established the Design/Build approach through the exemption process and by filing Findings supporting the use of this approach. The Design/Build approach was established in lieu of the more traditional Design-Bid-Build in order to take advantage of a fast track delivery approach.

The selection process will be conducted in a fair and impartial manner, where several qualified individuals will evaluate Proposals and presentations. The selection process has three major parts: 1) Proposal evaluation and initial ranking; 2) interviews, reference checks, final ranking and selection; and 3) contract negotiation. See RFP Attachment C regarding the Sample Contract.

The initial selection will be based on a combination of qualifications and price for the Program Refinement and Schematic Design Phase. At the end of the Schematic Design, the DBC will present a GMP Proposal including detailed backup documentation. Following review and acceptance of the GMP Proposal, the Port and the DBC will execute a Guaranteed Maximum Price ("GMP") Amendment. The GMP must be inclusive of all further design costs and all construction related costs necessary to deliver the Boat Launch and Marina facilities.

If the Port is unable to successfully agree upon a Guaranteed Maximum Price for the Project with the selected DBC, the Port reserves the right, in the exercise of its sole discretion, to enter into negotiations with next highest ranked Proposer. All Program Refinement and Schematic Design will be deemed work made for hire, with all ownership interests vesting in the Port, and in the event that the Port and the DBC cannot agree on a GMP, all Schematic Design Phase work will be turned over to the Port in paper and electronic format.

The selection process will be conducted as follows:

- A. The Port will publish the notice of the RFP in the Daily Journal of Commerce and any other publication it deems necessary.
- B. The Port will convene an evaluation committee made up of four to six qualified members, representing the Port, stakeholders or the general public to evaluate all Proposals.

C. The evaluation committee will provide an initial ranking of the DBC teams and reserves the right to interview one or more of the top ranked DBC's. Based on the results of the interview process, the proposals may be re-ranked. (The evaluation criteria and related points are set forth in Section IV.)

D. The Port will attempt to negotiate a contract with the top ranked firm. If negotiations are not successful within fifteen (15) calendar days, the Port, at its sole discretion, may then negotiate with the second ranked firm, and so forth. The Port reserves the right to reject any or all Proposals for good cause upon a finding that it is in the public interest to do so. Execution of the Design/Build Agreement will be contingent upon approval of and funding for the project.

## B. SCHEDULE FOR SELECTION

The milestones for the selection process are set forth below. Required dates for submittals and any other activities are provided elsewhere in this Request for Proposals:

<u>PROJECT MILESTONE</u>	<u>COMPLETION DATE</u>
Advertise RFP	August 10, 2018
RFP Document Available	August 10, 2018
Mandatory Pre-Proposal conference	September 5, 2018, 11:00 a.m.
Deadline for Written Questions	September 10, 2018, 5:00 p.m.
Issue any final Addenda	September 14, 2018
Due Date for Submission of Proposals	September 20, 2018 2:00 p.m.
Interviews	October 4, 2018*
Notice of Tentative Award	October 5, 2018*
Deadline for Selection Protests	October 15, 2018*
Execute Contract	October 19, 2018*
Notice to Proceed	October 19, 2018*
GMP Proposals Due	January 31, 2019*
Execute GMP Amendment	February 7, 2019*
In-water Work Period	November 1, 2019- February 15, 2020
Substantial Completion	March 31, 2020*

\* Indicates dates to be confirmed.

### III. SERVICES TO BE PROVIDED

#### A. DESCRIPTION OF SERVICES

1. **Program Refinement and Schematic Design Phase Services:** In the Program Refinement and Schematic Design Phase, the DBC, through its design consultants and in consultation with the Owner, shall provide those services necessary to refine the preliminary program (Attachment B — Design/Build Criteria — Volume 1) prepare schematic design documents consisting of drawings and other documents illustrating the general scope, scale and relationship of the Project components and evaluation of cost effective measures for incorporation into the project for approval by the Owner. Following the Schematic Design Phase the DBC shall provide to the Port a GMP Proposal with detailed backup outlining all further design costs, construction costs, labor, materials, equipment, permitting, overhead, incidental items, profit and contingency associated with the Project. Following negotiation and approval of the GMP Proposal, the Port and the DBC will execute a GMP Amendment for the detailed design and construction services.
  
2. **Design and Construction Phase Services:** During the Design and Construction Phase Services, the DBC shall provide all design services necessary to fully document and describe the details necessary for the construction of a fully functional boat launch and marina. These services include, but are not necessarily limited to: All architectural, site/civil, mechanical, structural, and electrical engineering necessary to support the requirements of the project. During this phase the DBC shall also provide all materials, tools, equipment, labor, and professional and non-professional services, and shall perform all other acts and supply all other things necessary to fully and properly perform and complete the Work, as required by the Contract Documents, State and local codes and environmental requirements. The DBC will provide all necessary permits and approvals and provide all necessary documentation to the execution of this work. The DBC will also be responsible for ongoing management of the construction budget and Project schedule.

#### B. SPECIAL REQUIREMENTS

In order to implement the Design/Build method of construction with a Guaranteed Maximum Price (GMP), the Port will impose some special requirements to ensure an adequate level of competition.

Proposers shall note the following requirements concerning management of this GMP Project:

1. The processes used to award subcontracts by the DBC will be monitored by the Port and shall be reported to the Port on a quarterly basis.

## C. SAMPLE CONTRACT AND NEGOTIATIONS

The successful proposer will enter into a contract with the Port substantially in the form attached hereto as **Attachment C** (Sample Design/Build Agreement) including the State of Oregon General Conditions for Public Improvement Contracts (1/1/2010) ("General Conditions"). The General Conditions, as may be modified by Supplemental General Conditions, if any, shall apply to the work of all subcontractors and to the work of the DBC to the extent that they do not conflict with the Design/Build Agreement.

The selected DBC will be required to comply with BOLI Prevailing Wage Rates for Public Works Contracts in Oregon.

Prior to entering into a contract, the selected DBC will be required to submit to the Port any and all information reasonably requested by the Port to verify that the selected DBC is licensed, insurable and financially sound to a level that satisfies the Port.

During contract negotiations following selection of the highest ranked Proposer, the Port will entertain suggestions on refinement of the Design/Build Agreement and its Exhibits only when:

1. the general work scope remains the same; and
2. the field of competition does not change as a result of material changes to the requirements stated in the RFP, and

The intent of these provisions is to avoid any unfair competitive advantage or disadvantage in the procurement process. Alternative approaches to structuring the GMP are contemplated and allowable under these negotiations. The Port intends to complete negotiations and enter into a contract within fifteen (15) days of Notice of Tentative Award, but reserves the right to extend that time at its sole discretion.

## IV. PROPOSAL REQUIREMENTS

### A. SUBMITTAL REQUIREMENTS

1. Date, time, and location: Interested Design Build firms must submit their Proposals no later than September 21, 2018 2:00 p.m. Submittals shall be mailed or delivered to:

Roxie Cuellar / Port Manager  
Port of Alsea  
365 Port Street  
Waldport, Oregon 97394  
Phone: (541) 563-3872  
Email: [rcuellar@portofalsea.com](mailto:rcuellar@portofalsea.com)

2. Late submission: A Proposal shall be considered late if received at any time after September 21, 2018 2:00 p.m. Proposals received after the specified time shall be rejected.
3. Number and Form: Proposers submitting paper proposals shall submit six (6) copies of its Proposal to the above location. The Proposals shall be tabulated in separate sections with separator sheets in response to the detailed Proposal requirements. All materials shall be 8-1/2" x 11" format, bound vertically (11" side) in a type no smaller than 10 point. No other material should be submitted.



Proposals may also be submitted in PDF form to rcuellar@portofalsea.com. All signatures on electronically submitted proposals shall be scanned copies of the originals and shall be legally binding.

4. Proposal Certification Statement: Attachment A - Proposal Certification Statement shall be filled out and signed, and shall be included at the beginning of each Proposal. The certification shall bind the Proposer to perform the services for the fees stated in their Proposal. Failure to submit a signed Proposal certification statement will result in disqualification of the proposing firm.
5. Modification or Withdrawal of Proposal: Prior to the date and time designated for receipt of Proposal, any Proposal may be modified or withdrawn by notice to the Port at the place designated for receipt of Proposals. Such notice shall be in writing over the signature of the Proposer and shall be delivered on or before the date and time set for receipt of Proposals.
6. Written Questions and Addenda: Questions regarding the information contained in this Request for Proposals must be submitted to the designated RFP contact no later than the time and date specified in Section II (B) of this RFP. All questions must be submitted in writing and received by the specified date and time. No oral questions will be accepted other than at the mandatory pre-proposal conference.

Emailed questions will be accepted at rcuellar@portofalsea.com, attention Roxie Cuellar, Port Manager. All questions received that materially affect this RFP will be answered by addenda. Anonymity of the source of the specific questions will be maintained in the written responses.

7. Mandatory pre-proposal conference: A mandatory pre-proposal conference will be held on September 5, 2018, 11:00 a.m., 11:00 a.m. at the Port of Alsea located at 365 Port Street, Alsea, OR 97394. The pre-proposal conference will be the Proposers' main opportunity to discuss the Project with the Port, and the Project Manager. An addendum will be issued following the conference if necessary to formalize any Port responses to Proposer questions.

**It is mandatory that the potential Proposers attend this Pre-Proposal Conference. Proposals will not be accepted from Proposers who do not attend.**

8. Insurance Requirements: During the term of any Design/Build Agreement resulting from this RFP, the Contractor shall maintain in force, each policy required by the Contract Documents (see Section G of the General Conditions and the Supplemental General Conditions, if any). A Contract will not be executed, and the Port will not issue a notice to proceed, until acceptable proof of coverage is received.
9. Bonding Capacity: Each Proposer must be capable of providing a 100% performance bond and 100% payment bond for the Project in the amount of the construction budget, currently valued at approximately \$2.5 million in construction costs.
10. Public Records:
  - a. This RFP and one copy of the subsequent selected Proposal(s), together with copies of all documents pertaining to the award of a Contract, shall be kept by the Port and made a part of a file or record, which shall be open to public inspection. If a Proposal contains any information that is considered a trade

secret under ORS 192.501(2), each sheet of such information shall be marked with the following legend:

"This data constitutes a trade secret under ORS 192.501(2) and shall not be disclosed except in accordance with the Oregon Public Records Law, ORS Chapter 192."

- b. The Oregon Public Records Law exempts from disclosure only bona fide trade secrets, and the exemption from disclosure applies only "unless the public interest requires disclosure in the particular instance", ORS 192.501(2). Therefore, nondisclosure of documents or any portion of a document submitted as part of a Proposal may depend upon official or judicial determinations made pursuant to the Public Records Law.
- c. Fee schedule information, is not exempt from disclosure pursuant to the Oregon Public Records Law, and shall be open to public inspection.
- d. Identifying the Proposal in total as a trade secret is not acceptable. Failure to identify a portion of the Proposal as a trade secret shall be deemed a waiver of any future claim of that information as a trade secret.

- 11. Recyclable Products: Vendors shall use recyclable products to the maximum extent economically feasible in the performance of the Contract work set forth in this document.

## **B. DETAILED PROPOSAL REQUIREMENTS**

Every Proposal must reply to each of the following items. Responses must be in the same order listed below. Concise and direct answers are encouraged.

By listing individuals in the Proposal, the firm guarantees that these individuals will be available to work on the Project at the approximate percentages shown. The Port reserves the right to approve or reject any changes to the proposed personnel. The Port further reserves the right to request a substitution of personnel if deemed to be in the best interest of the Port.

- 1. Recent Experience
  - a. Both key design and construction entities must show recent experience in the delivery of at least one Boat Launch, Marina, or other similar marine facility within the past 5 years. Please provide a brief description of at least one boat launch, marina, or similar marine facility that each entity has designed and/or constructed within the past five (5) years.
- 2. Similar Project History/Safety
  - a. Provide a brief description of your team's history in the design and/or construction of boat launch, marina, or similar facilities within the past ten (10) years.

- b. Provide a list of projects done for government entities that involve the design or construction of boat launch, marina, or similar facilities within the past ten (10) years, and include the name and contact information for the Owner's representative.
- c. Provide a general description of your firm's safety programs.

3. Firm Experience/Design Experience

- a. Provide a listing, in chronological order, of your firm's completed projects of \$1 million or more (provide a list of at least 5). Information on these projects should include the following:
  - (1) Name of the owner, contact person, and current phone number
  - (2) The architect, contact person, and current phone number
  - (3) Location of the project and completion date
  - (4) A brief description of the job
  - (5) Amount of Contract award or negotiated GMP (if applicable)
  - (6) Final contract amount, and total amount of change orders
  - (7) Total project claims going to litigation/arbitration and their disposition
  - (8) Identify projects completed as a Design/Build project.
- b. Provide a listing of experiences with Design/Build projects and whether they were for public or private sector clients. The listing should follow the format described in section 3a, but should include both the award amount, and the final Cost of the Work.

4. Staffing & Staff Qualifications

- a. Provide a Project organization chart showing your proposed staff for this Project, including all professional staff in the following areas: professional design consultants; project management; corporate oversight and administration; estimating; and on-site construction supervision.
- b. Include resumes for all key individuals listed in the chart. Indicate the proposed percentage that each person will work on this Project during Program Refinement and Schematic Design Phase and the Design and Construction Phase Services. The resumes must include each individual's education, work history, length of tenure with the firm, and prior work experience with similar projects and any experience working with public sector GMP projects.
- c. For those individuals who are not full time, describe how and when they will work on the Project, as well as which other Project responsibilities will fill their time. Additionally, describe the prior experience, if any, of the team members working with each other on projects (please be specific) and what roles they will fill on the proposed team for this Project.

5. Project Approach

- a. Describe how your firm will approach the Program Refinement and Schematic Design, design, construction, and construction management aspect of this Project and how will you ensure that the Project's needs are adequately met.

- b. Describe your firm's overall plan to complete the Project. Discuss in detail your plan, identifying your services and deliverables to the Owner during the Schematic Design phase. These services shall include, but are not limited to reviewing the program and budget, recommendations on feasibility, alternate designs, drawings, constructability reviews, value engineering, scheduling, cost estimating, bidding market, etc. Discuss in detail your plan during the Construction Phase Services, identifying your services and deliverables to the Owner during this phase. These services shall include, but are not limited to creating bid packages, bidding, scheduling the work, managing the construction, meetings, written reports, cost control, etc., so as to provide the Owner with the best possible customer service and ensure the greatest possible value for the construction budget.

## 6. Fees

- a. Consultant shall include a statement of: 1) the maximum Program Refinement and Schematic Design Fee (to be billed on a cost reimbursement basis); 2) a completed Attachment F - Categories of General Conditions Work, outlining the fixed cost of General Conditions; and 3) the Design/Build Fee, expressed as a fixed percentage of the Cost of Work.

## 7. General Conditions Work

- a. Proposers are required to complete the table in Attachment F to indicate estimated General Conditions Work costs associated with the Central Data Center Design/Build project and submit the completed table with their Proposal. These costs will not be scored or considered as part of the evaluation to select the apparent successful Proposer, but these costs, when finally negotiated, will become part of the final contract with the selected DBC. The Port reserves the right to negotiate the cost of individual items of General Conditions Work listed in the table in Attachment F. Any item of Work not included in the table in **Attachment F** but otherwise described in Article 7 of the sample Design/Build Agreement attached to this RFP shall be reimbursed not as General Conditions Work but as Cost of the Work.

## **C. PUBLIC INFORMATION**

Proposals become public records upon submission, and are subject to public inspection following contract award unless otherwise exempt under Oregon's Public Records Law (ORS Chapter 192). "Trade Secrets" are conditionally exempt under ORS 192.501(2), and will be protected to the extent permitted by the Public Records Law, provided that any trade secret is specifically identified as such by Proposer.

## **D. INTERVIEW INFORMATION**

1. Interview(s) of the top ranked Proposers are tentatively scheduled for October 4, 2018. The firm(s) will be notified of the time and place for the interviews. The format of the interview will allow time for the presentation of the Proposal by the proposing firm. The Design/Build project manager, key design consultants and onsite superintendent listed in the Proposal must be present at the interview. Following the presentation of the Proposal, The Port will ask questions designed to clarify and expand on the information contained in the Proposal.

2. At the time of notification, any required supplemental information will be provided to the firm(s). The Proposer must address any exceptions, or confirm acceptance of the Design/Build Agreement, **Attachment C**, at the time of the interview.

**E. EVALUATION CRITERIA**

Proposals not submitting all required information and documents, and not including all requested information for evaluation under the evaluation criteria cited below, may be considered non-responsive and may be rejected. Each Proposal shall contain the desired information in the format specified. Responsive Proposals will be evaluated in accordance with the following:

Reference numbers below are from Section IV, Proposal Requirements, B. Detailed Proposal Requirements, which indicate the scope of each criterion. Points listed below are the total possible points, which can be awarded for each criterion.

Criteria	Points	Reference
1 a) Recent Experience	Pass or Fail	1 a
1 b) General Conditions work	Pass or Fail	8a

*If proposal fails in this first category, then it will not be reviewed any further*

2 ) Similar Project History/Safety	25	2a, b & c
3 ) Firm History/Design Experience	15	3a & b
4 ) Staffing and Staff Qualifications	15	4a, b, & c
5 ) Project approach	25	5a & b
6 ) Fees	20	6a
TOTAL POSSIBLE SCORE	100	

**F. FINAL SELECTION**

1. Based on the initial scoring, The Port will determine the number of top ranked firms that will be invited for interviews. During the interview, the Proposers will be given the opportunity to present their proposal. Following the presentation, the interview panel will ask questions to supplement and clarify the proposal. While the interview sessions will not be independently scored, the interview process will be used to supplement and clarify the information contained in the Proposal, but not to modify the Proposal. Based upon the Proposal scoring, as modified by information obtained during the interviews, and results of reference checks, the firms will be given final ranking by the evaluation committee.

2. The Port may negotiate changes to the Design/Build Agreement as long as the general scope of the Work remains the same.
3. The Port will attempt to negotiate a Design/Build Agreement for Schematic Design Services with the top ranked than. If negotiations are not successful within fifteen (15) calendar days, the Port, at its sole discretion, may then negotiate with the second ranked firm, and so forth.

## **V. PROTESTS AND REQUESTS FOR CHANGE.**

### **A. SOLICITATION PROTESTS AND REQUESTS**

Pursuant to OAR 137-030-0050, a Proposer may file a written protest or make a written request that the Port change an RFP specification or contract term. ANY PROTEST OR REQUEST FOR CHANGE MUST BE DELIVERED IN WRITING TO Roxie Cuellar, Port Manager at 365 Port Street, Waldport, Oregon 97394. ON OR BEFORE SEVEN (7) CALENDAR DAYS PRIOR TO THE DUE DATE FOR PROPOSALS. The purpose of this protest/request for change procedure is to permit the Port to correct, prior to the submission of Proposals, specifications, or contract terms that may be improvident, unlawful or which may unnecessarily restrict competition. This requirement is intended to eliminate, by permitting corrections prior to the submission of Proposals, the waste of resources and delay that may result from the untimely detection of errors in the RFP, possible protests, and possible rejection of Proposals. The Port will consider each protest or request, amend the RFP accordingly if warranted, and will notify in writing, each perspective Proposer of any change. No amendment of this RFP shall be effective unless made in writing and signed by the Port Manager.

### **B. SELECTION QUESTIONS AND PROTESTS**

All Proposers who submit Proposals in response to this RFP will be notified in writing of the selection of the apparent successful Proposal, and will be provided an evaluation report of the selection process. Any questions about or protests of the selection process shall be directed to Roxie Cuellar, Port Manager, at 365 Port Street, Waldport, Oregon 97394. Pursuant to OAR 137-0300104, protests of adversely affected or aggrieved Proposers must be in writing, specify the grounds upon which the protest is based, and be delivered to the Port within ten (10) calendar days after the date of the Notice of Tentative Award. No protest or challenge of the award selection shall be considered after this time period.

**BOAT LAUNCH AND MARINA IMPROVEMENTS CONSTRUCTION PROJECT**

**ATTACHMENT A**

**Proposal Certification Statement**

Proposing Firm: \_\_\_\_\_

*Each Proposing Firm (offeror) must read and comply with the following sections. Failure to do so may result in bid/proposal (offer) rejection.*

**SECTION I**

**CERTIFICATION OF COMPLIANCE WITH DISCRIMINATION LAWS**

By my signature at the end of this Attachment A, I hereby attest or affirm under penalty of perjury: That I am authorized to act on behalf of Contractor in this matter, and to the best of my knowledge the Contractor has not discriminated against minority, women or emerging small business enterprises in obtaining any required subcontracts, and that the Contractor is not in violation of any Discrimination Laws.

**SECTION II**

**CERTIFICATION OF COMPLIANCE WITH TAX LAWS**

By my signature at the end of this Attachment A, I hereby attest or affirm under penalty of perjury: That I am authorized to act on behalf of the Contractor in this matter, that I have authority and knowledge regarding the payment of taxes, and that Contractor is, to the best of my knowledge, not in violation of any Oregon Tax Laws.

For purposes of this certification, "Oregon Tax Laws" means those programs listed in ORS 305.380(4) which is incorporated herein by this reference. Examples include the state inheritance tax, personal income tax, withholding tax, corporation income and excise taxes, amusement device tax, timber taxes, cigarette tax, other tobacco tax, 9-1-1 emergency communications tax, the homeowners and renters property tax relief program and local taxes administered by the Department of Revenue (Lane Transit District Self-Employment Tax, Lane Transit District Employer Payroll Tax, Tri-County Metropolitan Transit District of Oregon ("Tri-Met") Employer Payroll Tax, and Tri-Met Self Employment Tax).

**SECTION III**

**RESPONSIBILITY**

The Port of Alsea, (the Port), reserves the right, pursuant to OAR 125-030-0003, to investigate and evaluate, at any time prior to award and execution of the contract, the apparent successful offeror's responsibility to perform the contract. Submission of a signed offer shall constitute approval for the Port

**ATTACHMENT A**

to obtain any information the Port deems necessary to conduct the evaluation. The Port shall notify the apparent successful offeror, in writing, of any other documentation required, which may include, but is not limited to, recent profit-and-loss history; current balance statements; assets-to-liabilities ratio, including number and amount of secured versus unsecured creditor claims; availability of short and long-term financing; bonding capacity; credit information; material; equipment; facility and personnel information; performance record of contract performance; etc. Failure to promptly provide this information shall result in offer rejection.

The Port may postpone the award of the contract after announcement of the apparent successful offeror in order to complete its investigation and evaluation. Failure of the apparent successful offeror to demonstrate Responsibility, as required under OAR 125030-0003, shall render the offeror non-responsible and shall constitute grounds for offer rejection, as required under OAR 137-030-0100.

#### **SECTION IV DRUG-TESTING CERTIFICATION**

1. Pursuant to OAR 125-030-0014, the Offeror certifies by its signature on these solicitation document forms that it has a Qualifying Drug Testing Program in place for its employees that includes, at a minimum, the following:
  - a. A written employee drug testing policy,
  - b. Required drug testing for all new Subject Employees or, alternatively, required testing of all Subject Employees every 12 months on a random selection basis, and
  - c. Required testing of a Subject Employee when the Offeror has reasonable cause to believe the Subject Employee is under the influence of drugs.
2. A drug testing program that meets the above requirements will be deemed a "Qualifying Employee Drug Testing Program." An employee is a "Subject Employee" only if that employee will be working on the Project job site.
3. If awarded a Public Improvement Contract as a result of this solicitation, Offeror agrees that at the time of contract execution it shall represent and warrant to the Agency that its Qualifying Employee Drug Testing Program is in place and will continue in full force and effect for the duration of the Public Improvement Contract. The Port's performance obligation (which includes, without limitation, the Port's obligation to make payment) shall be contingent on Contractor's compliance with this representation and warranty.
4. If awarded a Public Improvement Contract as a result of this solicitation, Offeror also agrees that at the time of contract execution, and as a condition to the Port's performance obligation (which includes, without limitation, the Agency's obligation to make payment), it shall require each Subcontractor providing labor for the Project to:
  - (a) Demonstrate to the Contractor that it has a Qualifying Employee Drug Testing Program for the Subcontractor's Subject Employees, and represent and warrant to the Contractor that the

#### **ATTACHMENT A**



- Qualifying Employee Drug Testing Program is in place at the time of subcontract execution and will continue in full force and effect for the duration of the subcontract; or
- (b) Require that the Subcontractor's Subject Employees participate in the Contractor's Qualifying Employee Drug Testing Program for the duration of the subcontract.

**SECTION V**

**SIGNATURE OF OFFEROR'S DULY AUTHORIZED REPRESENTATIVE**

***THIS OFFER MUST BE SIGNED IN INK BY AN AUTHORIZED REPRESENTATIVE OF THE OFFEROR; ANY ALTERATIONS OR ERASURES TO THE OFFER MUST BE INITIALED IN INK BY THE UNDERSIGNED AUTHORIZED REPRESENTATIVE.***

The undersigned acknowledges, attests and certifies individually and on behalf of the Offeror that: (1) He/she is a duly authorized representative of the Offeror, has been authorized by Offeror to make all representations, attestations, and certifications contained in this bid/proposal document and all addenda, if any, issued, and to execute this bid/proposal document on behalf of Offeror; (2) Offeror, acting through its authorized representatives, has read and understands all bid/proposal instructions, specifications, and terms and conditions contained in this bid/proposal document (including all listed attachments and addenda, if any, issued); (3) Offeror certifies that this bid/proposal has been arrived at independently and has been submitted without any collusion designed to limit independent bidding or competition; (4) Offeror is bound by and will comply with all requirements, specifications, and terms and conditions contained in this bid/proposal document (including all listed attachments and addenda, if any issued); (5) Offeror will furnish the designated item(s) and/or service(s) in accordance with the bid/proposal specifications and requirements, and will comply in all respects with the terms of the resulting contract upon award; (6) OFFEROR WILL PROVIDE/FURNISH FEDERAL EMPLOYEE IDENTIFICATION NUMBER OR SOCIAL SECURITY NUMBER BELOW WITH BID/PROPOSAL SUBMISSION.

Authorized Signature:

Print Name: \_\_\_\_\_

Title: \_\_\_\_\_

FEIN ID# or SSN# (required): \_\_\_\_\_

Contact Person (Type or Print): \_\_\_\_\_

Telephone Number: (\_\_\_\_) \_\_\_\_\_ Fax Number: (\_\_\_\_) \_\_\_\_\_

**ATTACHMENT A**

# **BOAT LAUNCH AND MARINA IMPROVEMENTS CONSTRUCTION PROJECT**

## **ATTACHMENT B**

### **Design/Build Criteria Scope of Work**

The Port of Alsea is located on the Alsea River in Waldport, Oregon on the central Oregon coast. The Port facilities endure significant weather and tidal exchanges each year. The Port of Alsea is primarily a recreational facility, most vessels using the boat launch and marina are 16' - 19' and under. The largest vessels typically using the marina are 23'.

Current facilities at the Port of Alsea include a boat launch and marina. Both were built approximately 35 years ago and need to be replaced and expanded. A drawing of the existing boat launch and marina is can be found on Exhibit 2, page 2 of 5. The planned project involves:

- (a) Removal of the existing boat launch;
- (b) Construction of a new boat launch which will be designed and engineered by the Oregon State Marine Board;
- (c) Removal of the existing marina;
- (d) Design, engineering, and construction of a new marina facility.

Replacement of existing boat launch will involve removing and disposing the existing concrete ramp, abutment, wooden boarding float and steel piling; and installation of a new concrete ramp, abutment, boarding float, and piling. The boat ramp will be designed and engineered by the Oregon State Marine Board. OSMB has produced drawings of the proposed new boat launch. Those drawings are attached as Exhibit 1. The design and engineering of the boat launch has not been finalized and is subject to amendment.

Removing the existing marina will require, at a minimum, removing the existing support piles, bulkheads, gangways, and docks, with the exception of an existing boom and small attached dock on the east end of the existing marina. The new marina facility will require new piling, bulkheads, gangways, floating docks, and fingers. The Design Build Contractor will be responsible for designing and engineering a new marina facility with a minimum of 40 slips and 12 side ties. The side ties cannot be on the bay side of the outer dock. Piling for the new marina must be constructed on the inside of the floats. A working mock-up of the new marina facility is attached as Exhibit 2.

All drawings attached hereto are incorporated into this scope of work by reference herein.

The Port of Alsea is seeking a Design Build Contractor that can work with the engineers at OSMB on the boat launch portion of the project while designing and engineering plans for the marina portion of the

## **ATTACHMENT B**

project. The Design-Build Contractor will be responsible for developing and maintaining an efficient construction schedule to minimize down time and complete both projects within the in-water work period.

**ATTACHMENT B**

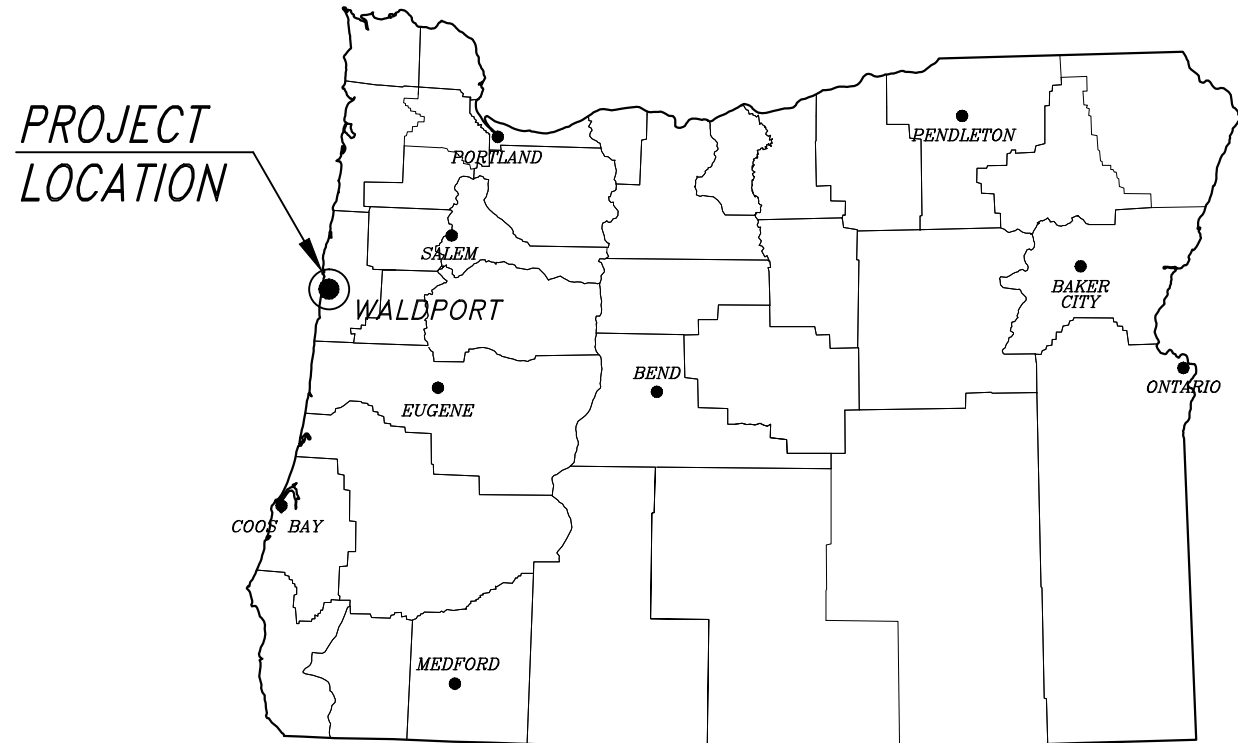

**LOCATION MAP**

NOT TO SCALE

**DRAWING INDEX**

- 1. TITLE SHEET
- 2. EXISTING SITE PLAN
- 3. REMOVAL PLAN
- 4. PROPOSED SITE PLAN
- 5. RAMP PLAN & PROFILE
- 6. RAMP CROSS SECTIONS

**GEOGRAPHIC LOCATION**

TOWNSHIP 13 SOUTH, RANGE 11 WEST, SECTION 19,  
 WILLAMETTE MERIDIAN, LINCOLN COUNTY, OREGON  
 LATITUDE 44°26'24" NORTH, LONGITUDE 124°03'30" WEST  
 USGS QUAD MAP: WALDPOR LANDING

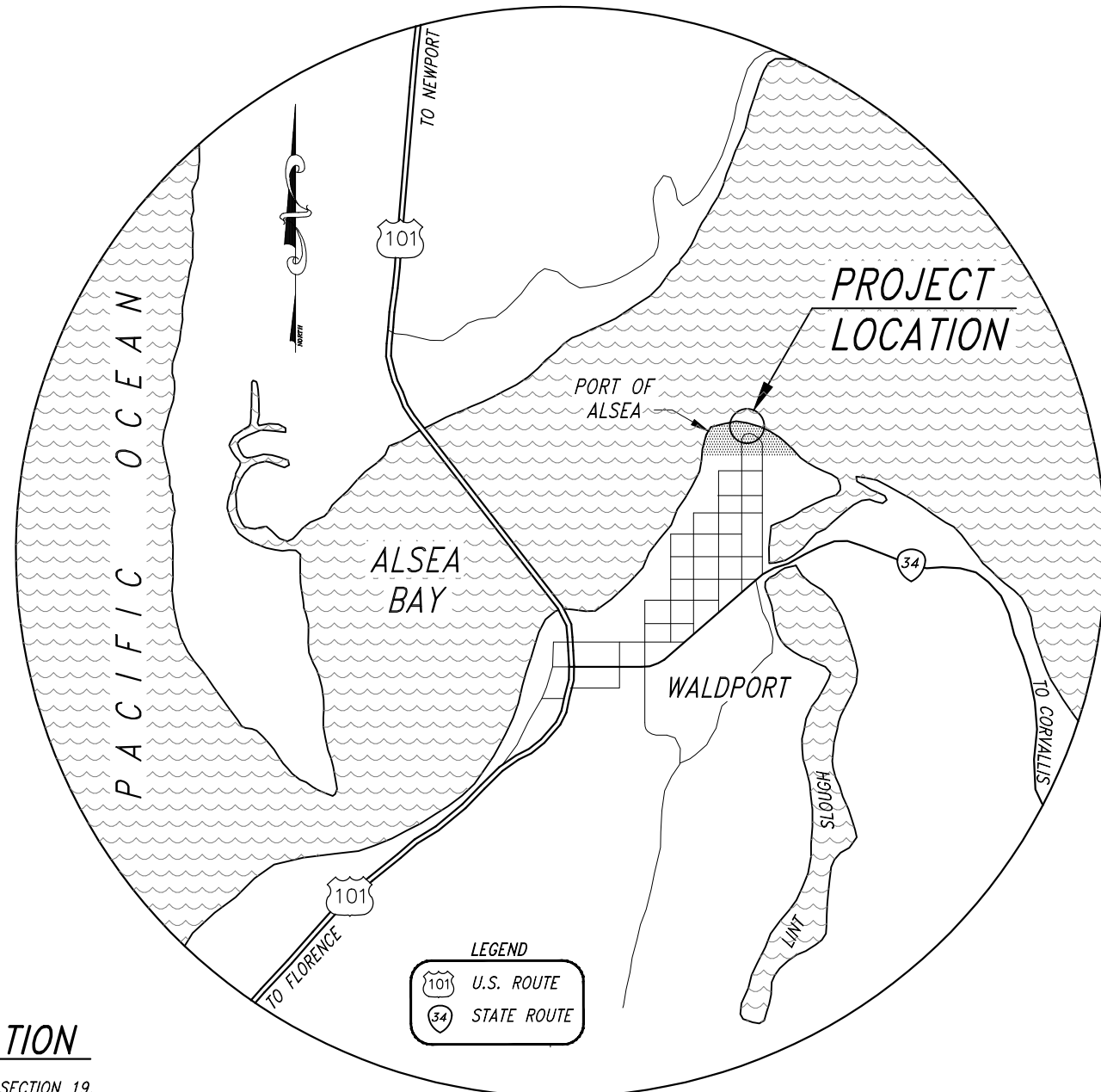

**VICINITY MAP**

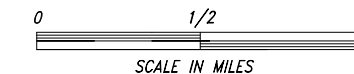

# BOAT RAMP & FLOAT REPLACEMENT PROJECT AT THE PORT OF ALSEA, ALSEA BAY FOR THE PORT OF ALSEA

**PERMIT REVIEW**  
 NOT FOR CONSTRUCTION

DATE	REVISIONS	BY

APPROVED FACILITIES MANAGER	DESIGNED BY	DATE
	K. PHELAN	05/15/13
FINAL CHECK BY	DRAWN BY	
	K. PHELAN	

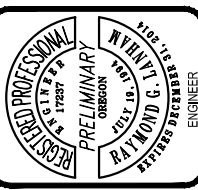

TITLE SHEET  
 AT THE PORT OF ALSEA, ALSEA BAY  
 FOR THE PORT OF ALSEA

OREGON STATE MARINE BOARD

1 SHEET	6 OF
2101 - NG - 1	
DRAWING NO.	

FILE PATH: I:\GIS\2013\Projects\2101-NG-1\Project\Port of Alsea\2101-NG-1.dwg  
 FILE NAME: 01 - Title Sheet.dwg

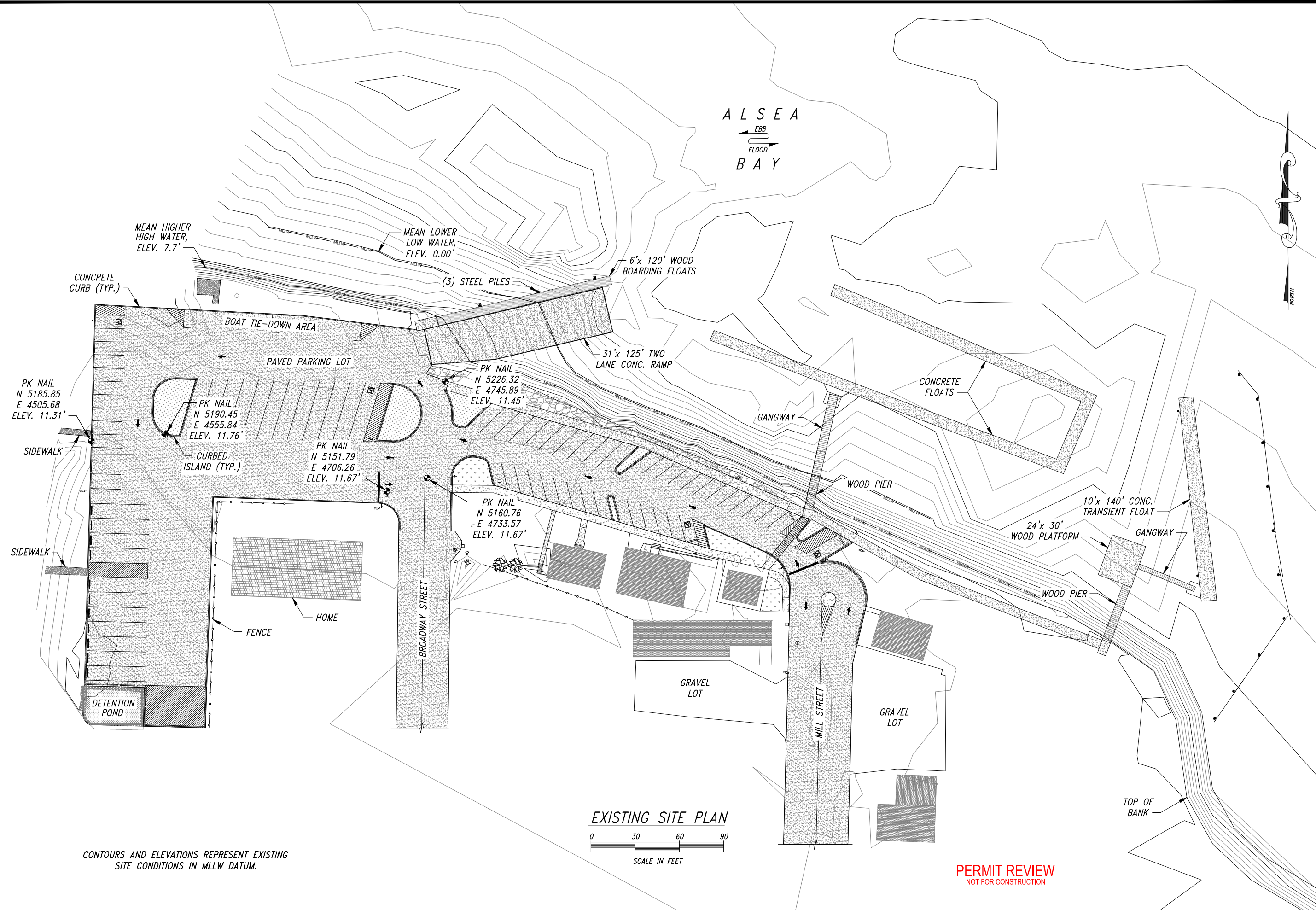

DATE	REVISIONS	BY

APPROVED BOATING FACILITIES MANAGER	DESIGNED BY	DATE
	R. LANHAM	05/15/13
FINAL CHECK BY	DRAWN BY	
	R. LANHAM	

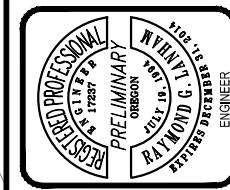

EXISTING SITE PLAN  
AT THE PORT OF ALSEA, ALSEA BAY  
FOR THE PORT OF ALSEA

**OREGON STATE MARINE BOARD**

2	6
SHEET	OF
2101 - NG - 2	
DRAWING NO.	

**PERMIT REVIEW**  
NOT FOR CONSTRUCTION

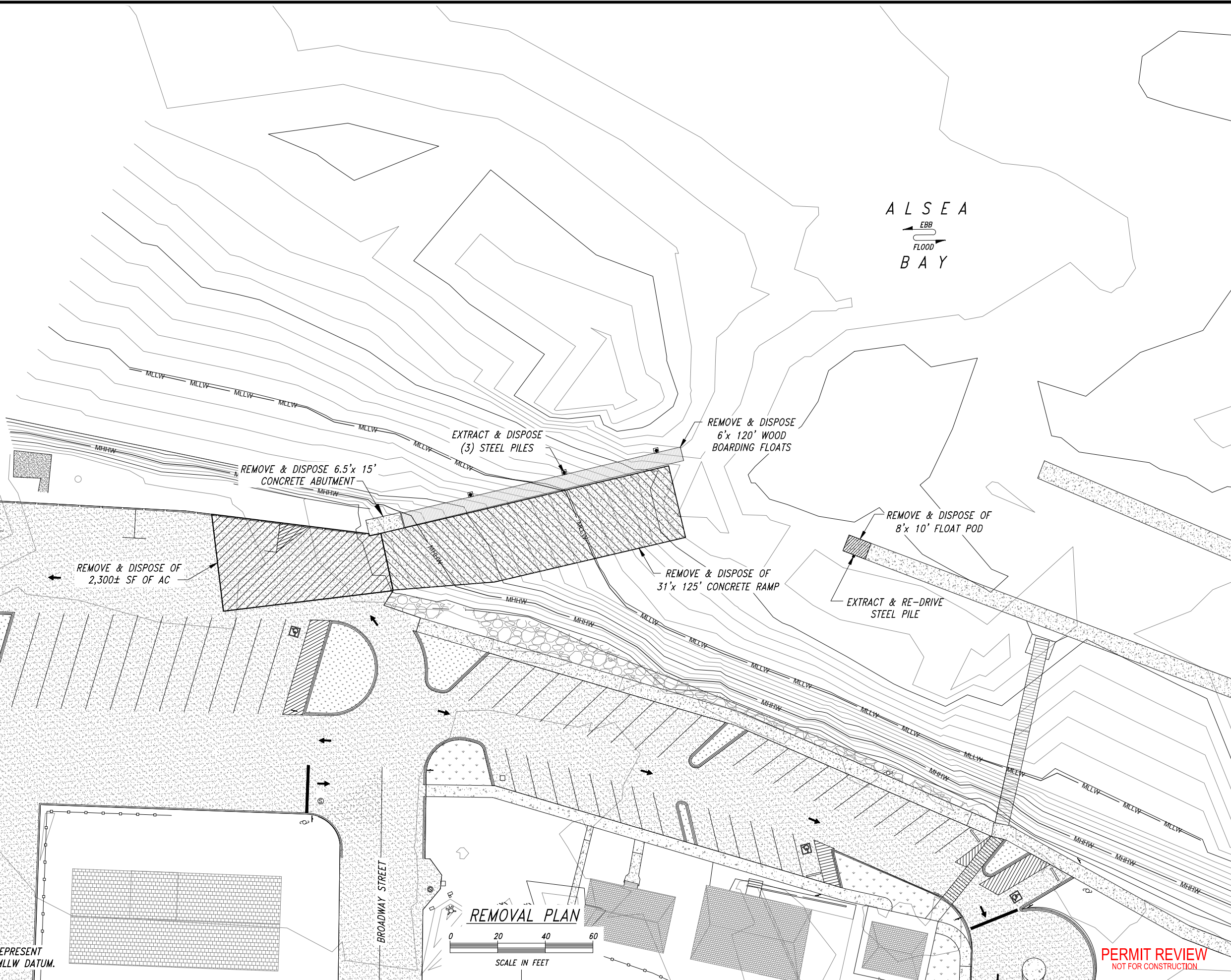

ALSEA  
EBB  
FLOOD  
BAY

REMOVE & DISPOSE OF  
2,300± SF OF AC

REMOVE & DISPOSE 6.5' x 15'  
CONCRETE ABUTMENT

EXTRACT & DISPOSE  
(3) STEEL PILES

REMOVE & DISPOSE  
6' x 120' WOOD  
BOARDING FLOATS

REMOVE & DISPOSE OF  
31' x 125' CONCRETE RAMP

REMOVE & DISPOSE OF  
8' x 10' FLOAT POD

EXTRACT & RE-DRIVE  
STEEL PILE

BROADWAY STREET

REMOVAL PLAN

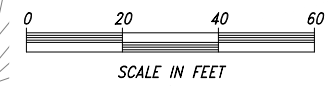

CONTOURS AND ELEVATIONS REPRESENT  
PROPOSED SITE CONDITIONS IN MLLW DATUM.

PERMIT REVIEW  
NOT FOR CONSTRUCTION

DATE	REVISIONS	BY

APPROVED BOATING FACILITIES MANAGER	
FINAL CHECK BY	R. LANHAM
DESIGNED BY	R. LANHAM
DRAWN BY	05/15/13
	DATE

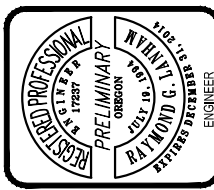

REMOVAL PLAN  
AT THE PORT OF ALSEA, ALSEA BAY  
FOR THE PORT OF ALSEA

OREGON STATE MARINE BOARD

3	6
SHEET	OF
2101 - NG - 3	
DRAWING NO.	

FILE PATH: I:\GIS\30\Projects\Alsea\Port of Alsea\Port of Alsea.dwg  
FILE NAME: 03 - Removal - Pgs. 3D.dwg



CONTOURS AND ELEVATIONS REPRESENT PROPOSED SITE CONDITIONS IN MLLW DATUM

PERMIT REVIEW  
NOT FOR CONSTRUCTION

DATE	REVISIONS	BY

APPROVED BOATING FACILITIES MANAGER	
FINAL CHECK BY	R. LANHAM
DESIGNED BY	R. LANHAM
DRAWN BY	05/15/13
	DATE

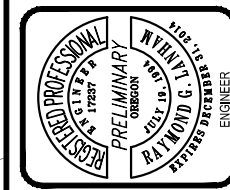

PROPOSED SITE PLAN  
 AT THE PORT OF ALSEA, ALSEA BAY  
 FOR THE PORT OF ALSEA  
 OREGON STATE MARINE BOARD

4	6
SHEET	OF
2101 - NG - 4	
DRAWING NO.	

FILE PATH: I:\GIS\3D\Projects\Alsea\ProposedPortOfAlsea\051313  
FILE NAME: 01 - Proposed Site Plan 3D 20 Scale.dwg

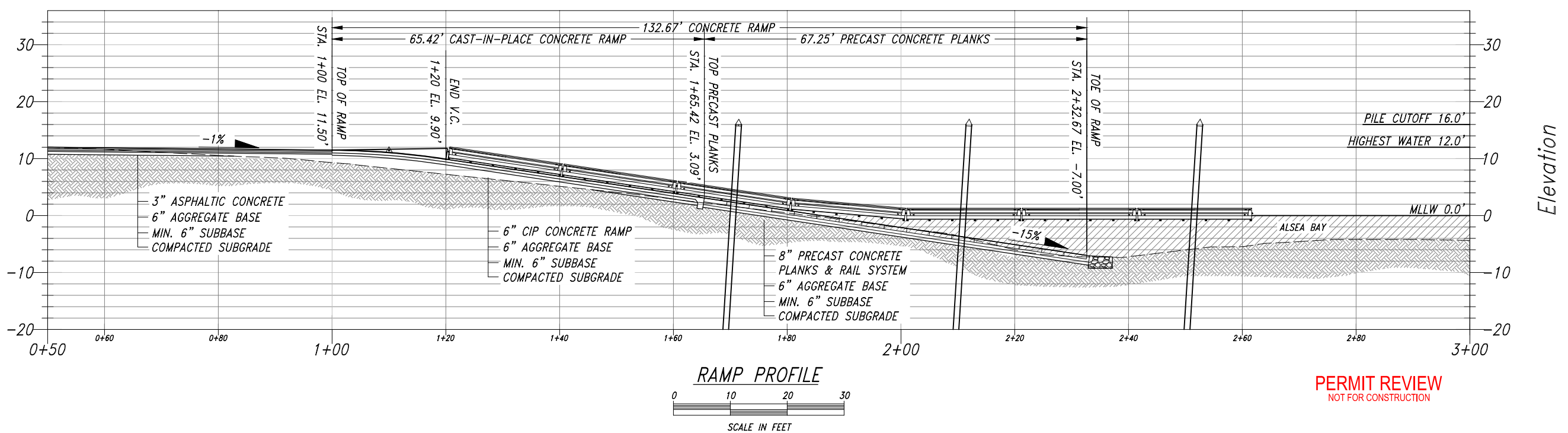
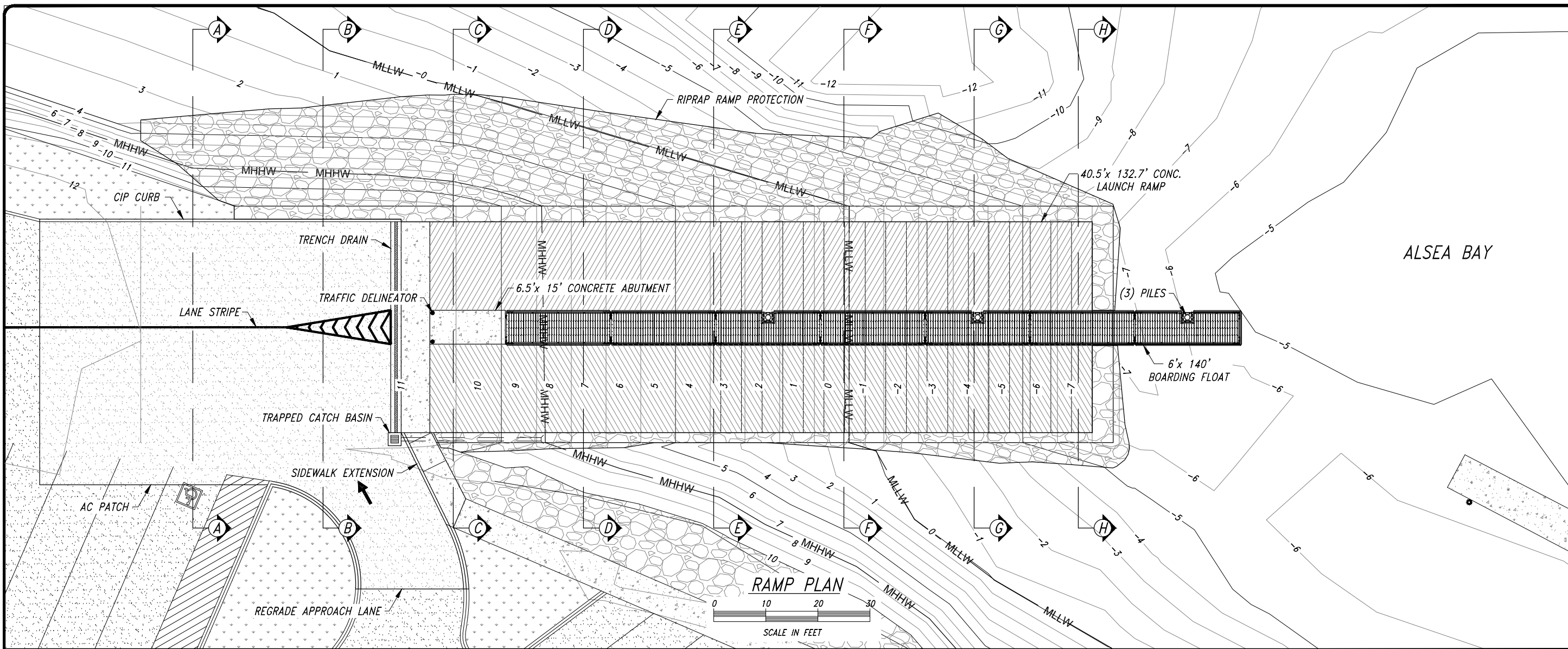

DATE	REVISIONS	BY

APPROVED FACILITIES MANAGER	DESIGNED BY	DATE
	R. LANHAM	05/15/13
FINAL CHECK BY	DRAWN BY	
	R. LANHAM	

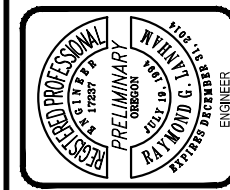

**OREGON STATE MARINE BOARD**

RAMP PLAN & PROFILE  
AT THE PORT OF ALSEA, ALSEA BAY  
FOR THE PORT OF ALSEA

5 SHEET	6 OF
2101 - NG - 5 DRAWING NO.	

PERMIT REVIEW  
NOT FOR CONSTRUCTION



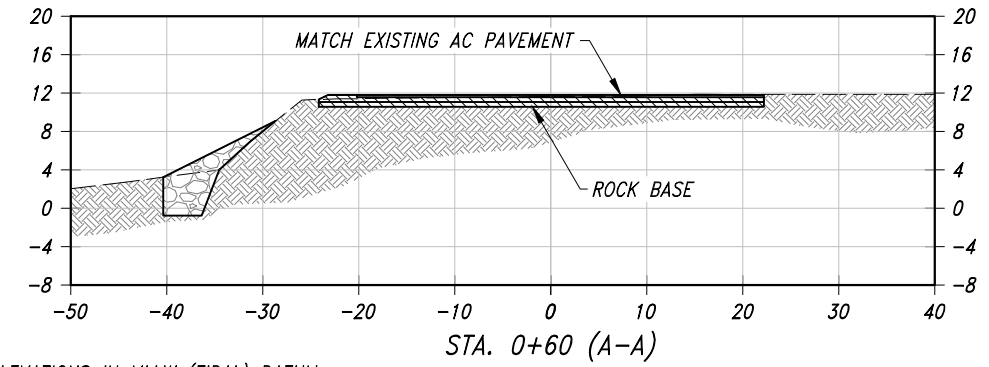
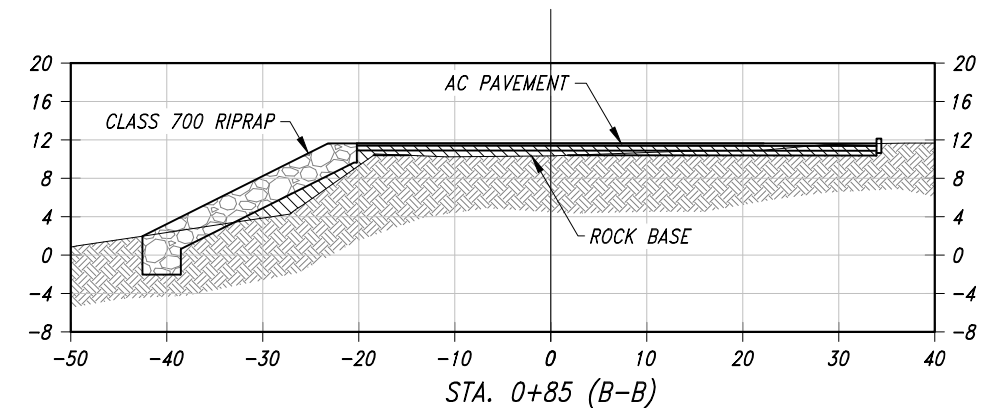
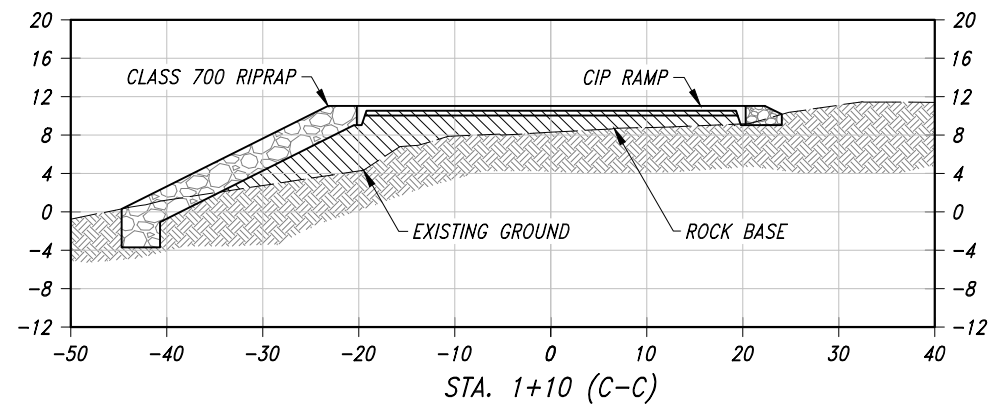
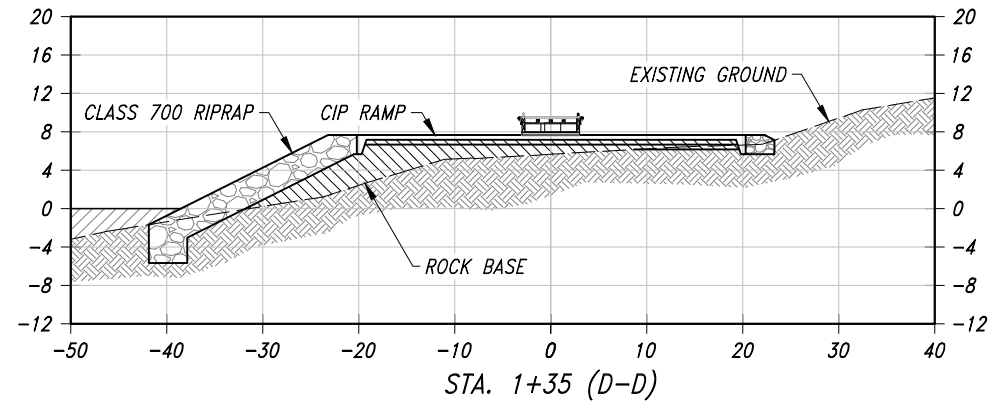

NOTE: ELEVATIONS IN MLLW (TIDAL) DATUM.

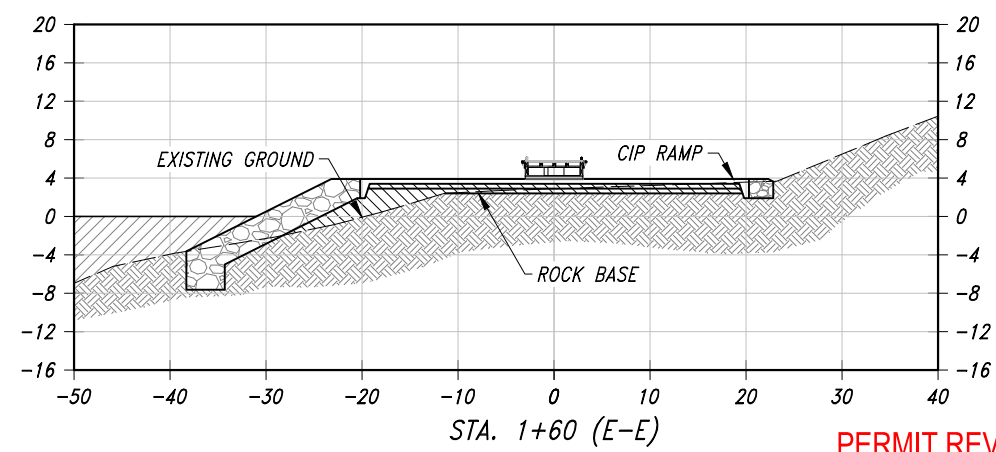
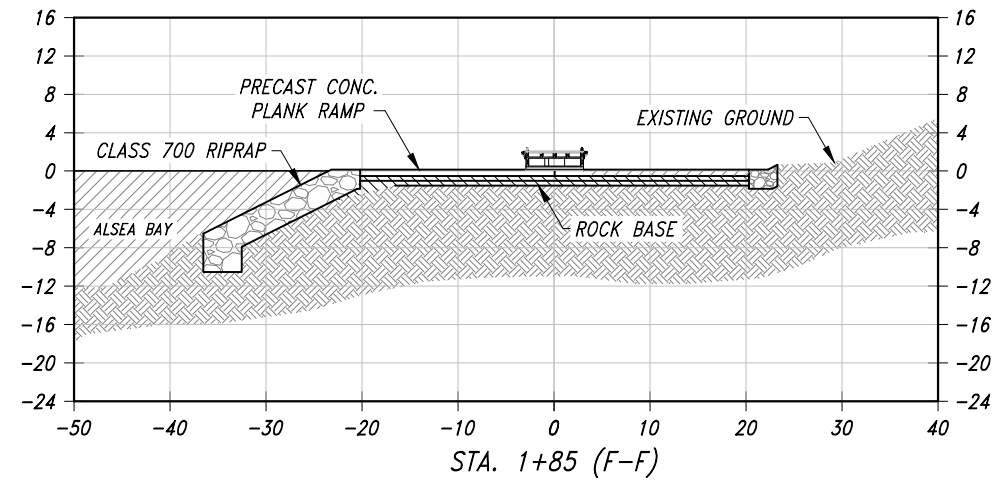
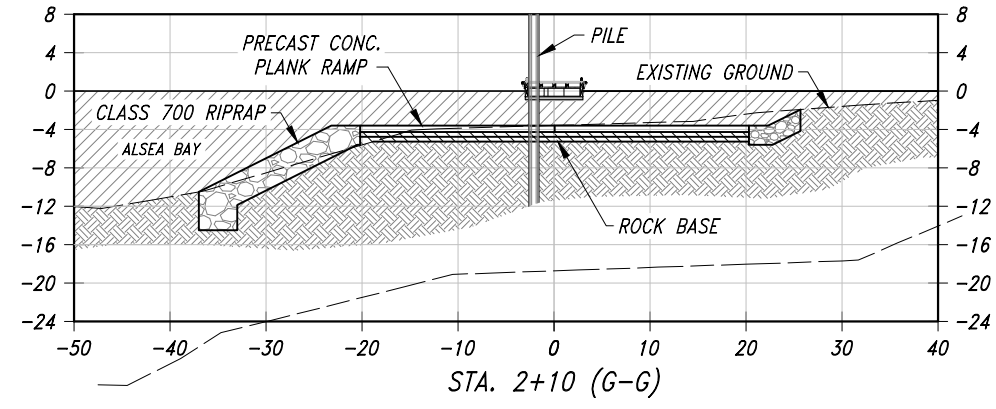
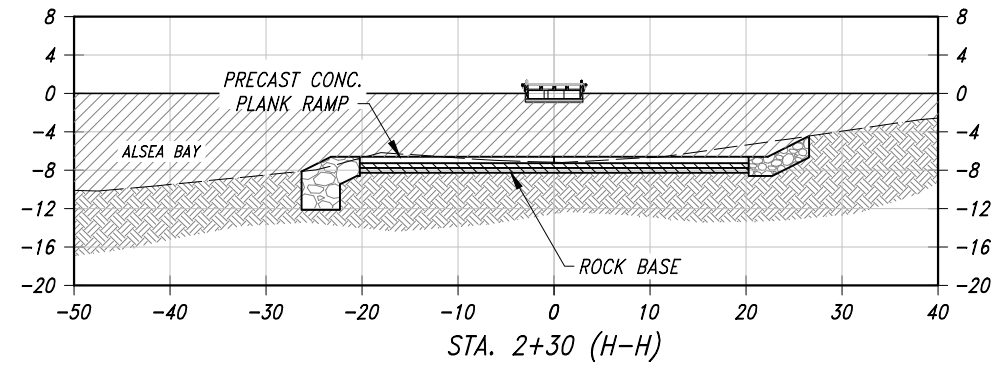
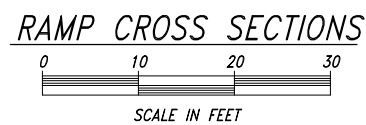

PERMIT REVIEW  
NOT FOR CONSTRUCTION

DATE	REVISIONS	BY

APPROVED FACILITIES MANAGER	DESIGNED BY	DATE
	R. LANHAM	05/15/13
FINAL CHECK BY	DRAWN BY	
	R. LANHAM	

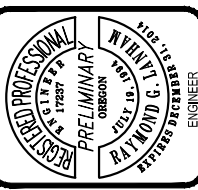

RAMP CROSS SECTIONS  
AT THE PORT OF ALSEA, ALSEA BAY  
FOR THE PORT OF ALSEA

OREGON STATE MARINE BOARD

6 SHEET	6 OF
2101 - NG - 6 DRAWING NO.	

FILE PATH: I:\GIS\2013\Projects\Port of Alsea\Port of Alsea\2101.dwg  
FILE NAME: 2101 - Ramp Cross Sections.dwg

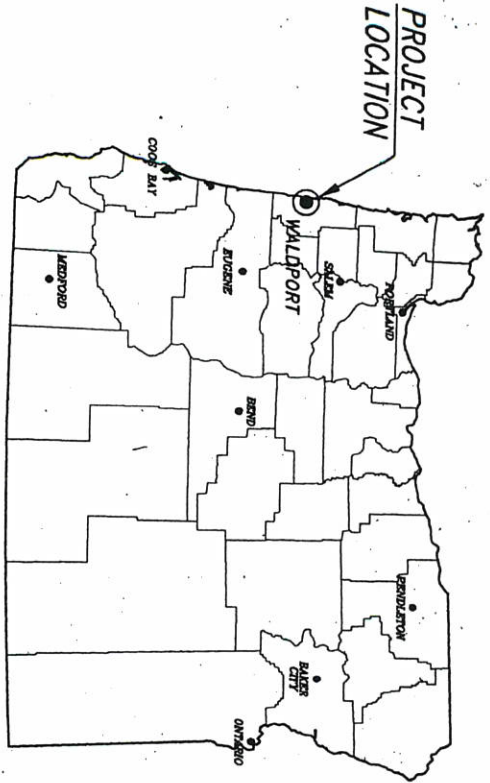

LOCATION MAP

NOT TO SCALE

DRAWING INDEX

GEOGRAPHIC LOCATION

TOWNSHIP 13 SOUTH, RANGE 11 WEST, SECTION 19,  
 WILMAMETTE METROPOLITAN, LINCOLN COUNTY, OREGON.  
 LATITUDE 44°26'24" NORTH, LONGITUDE 124°03'50" WEST  
 USGS QUAD MAP: WALDPORTR LANDING

REPLACEMENT PROJECT FOR:

PROPOSED MARINA FLOATING DOCK W/NEW GANTRY, FLOATING  
 CRAB DOCK W/NEW GANTRY, AND FIXED CRABPING PLATFORM  
 W/NEW FIXED ACCESS PIER.

AT THE PORT OF ALSEA, ALSEA BAY  
 FOR THE PORT OF ALSEA

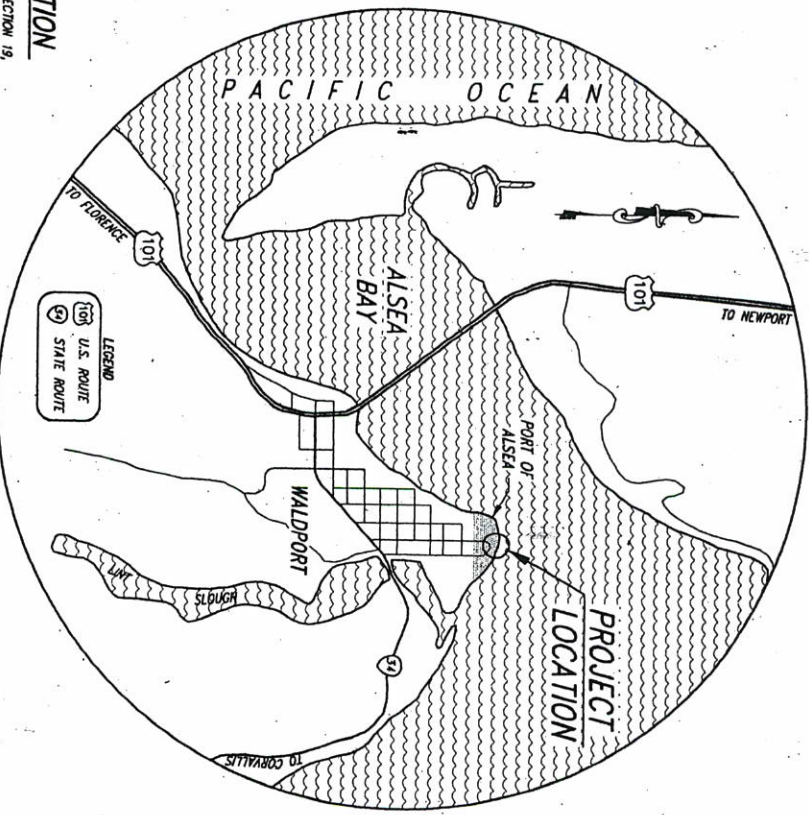

VICINITY MAP

0 1/2 1  
 SCALE IN MILES

LEGEND  
 101 U.S. ROUTE  
 50 STATE ROUTE

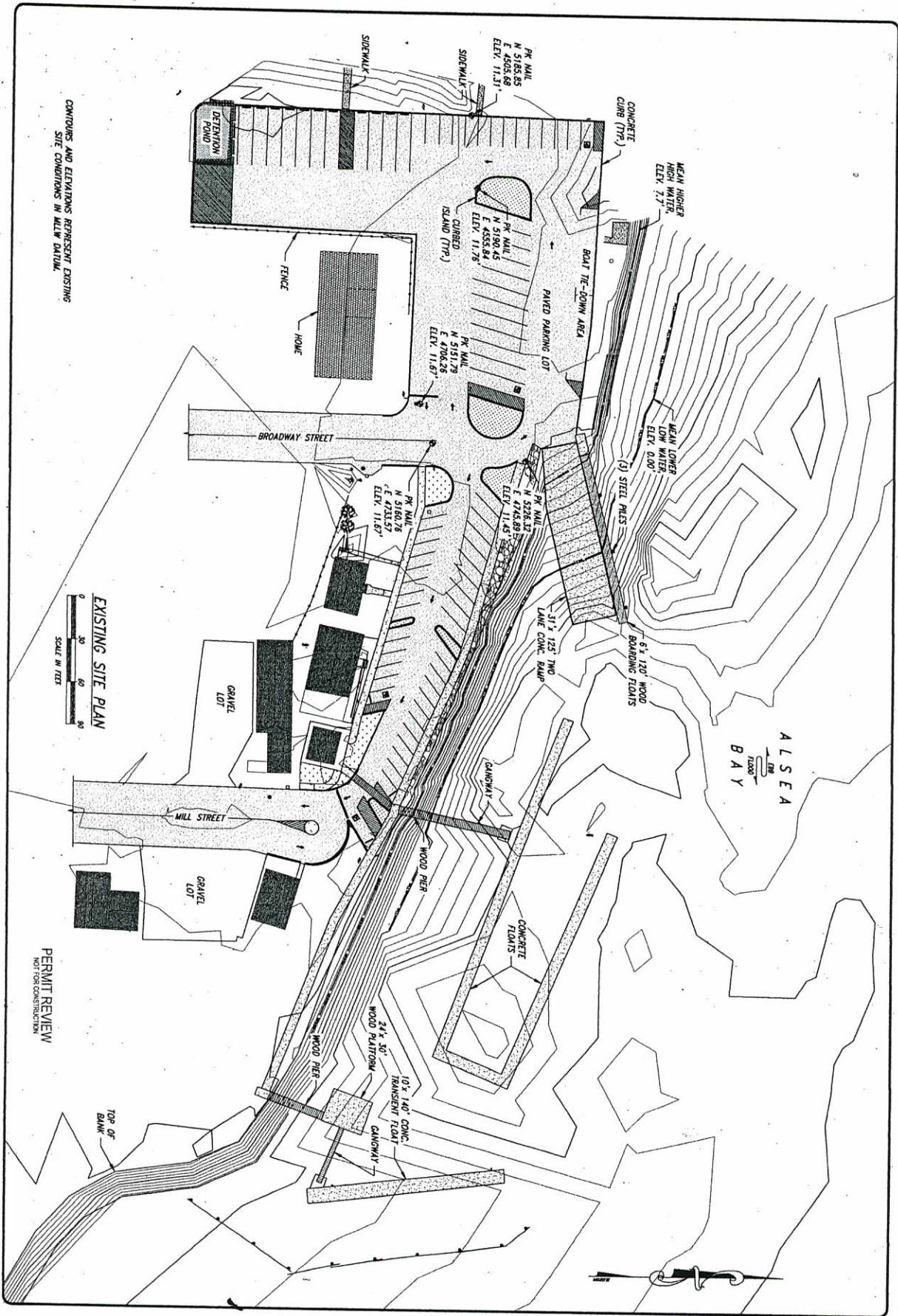

CONTOURS AND ELEVATIONS REPRESENT EXISTING SITE CONDITIONS IN ALLW DATUM.



PERMIT REVIEW NOT FOR CONSTRUCTION

PORT OF ALSEA  
SCALE 1"=100.0'

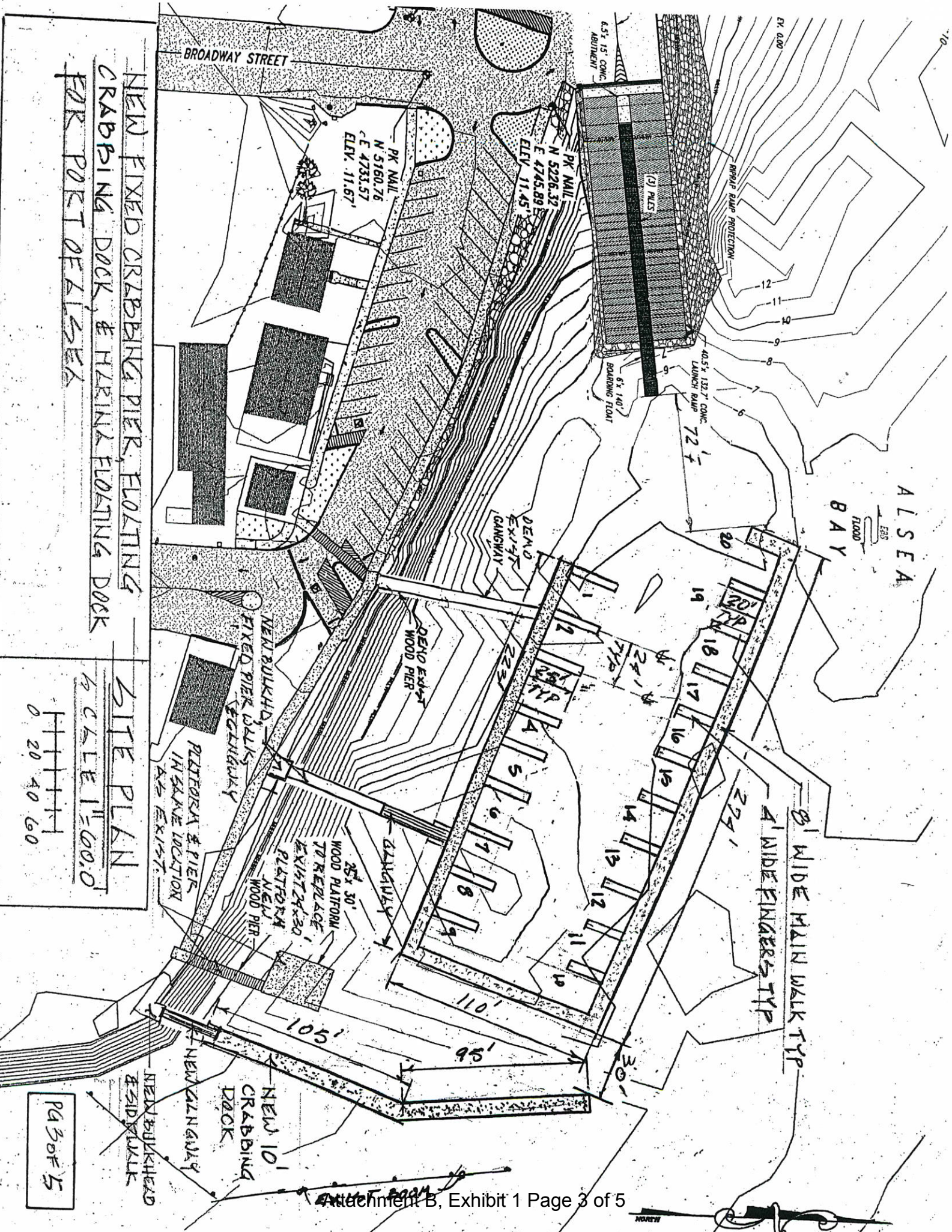

NEW FIXED CRABBING PIER, FLOATING  
 CRABBING DOCK, & MARINA FLOATING DOCK  
 FOR PORT OF ALSEÁ

SITE PLAN  
 SCALE 1"=600.0'

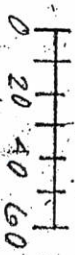

Pg 3 of 5

PRELIMINARY PILE  
 LOCATION, 40' OC ±  
 FINAL DESIGN  
 BY OTHERS

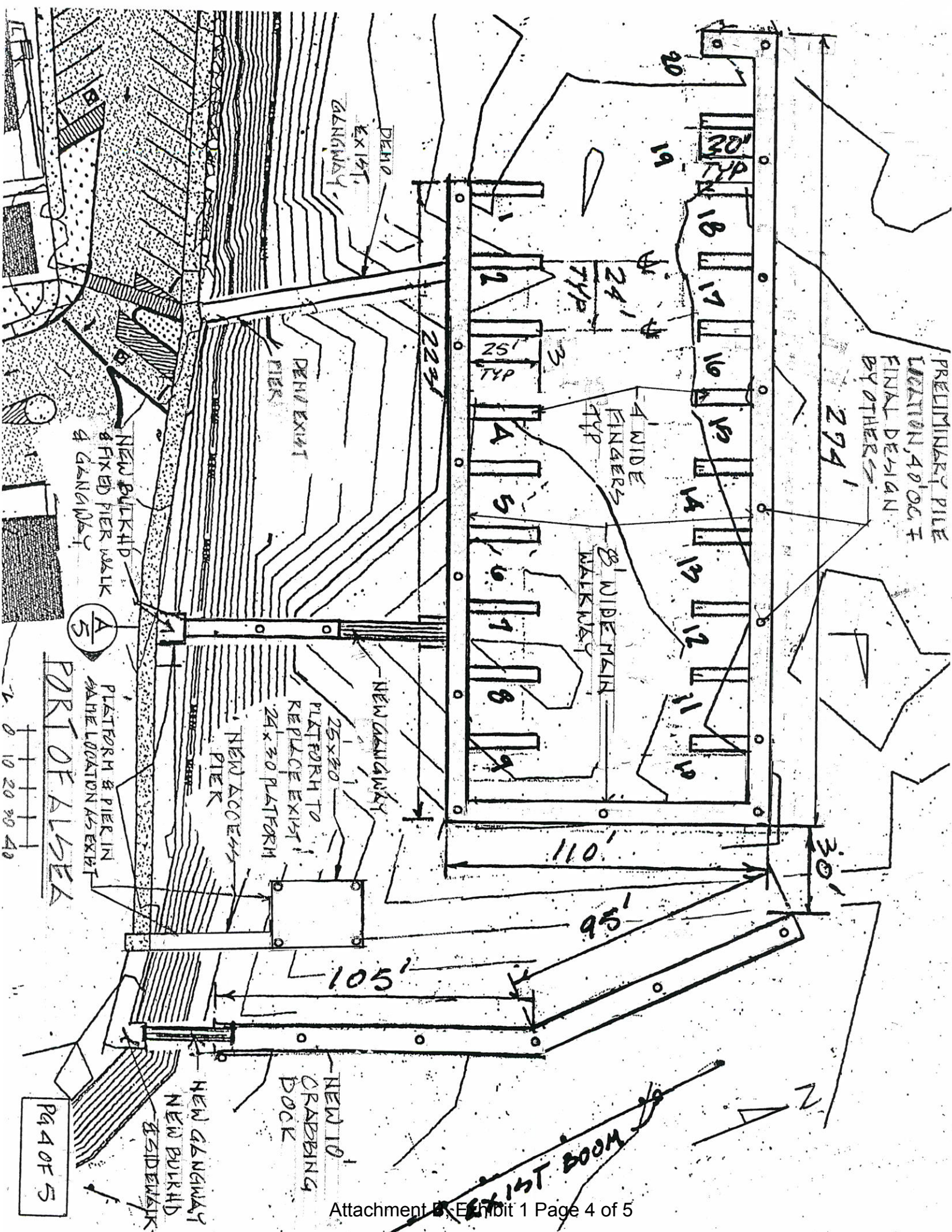

PORT OF ALBEE

A/S

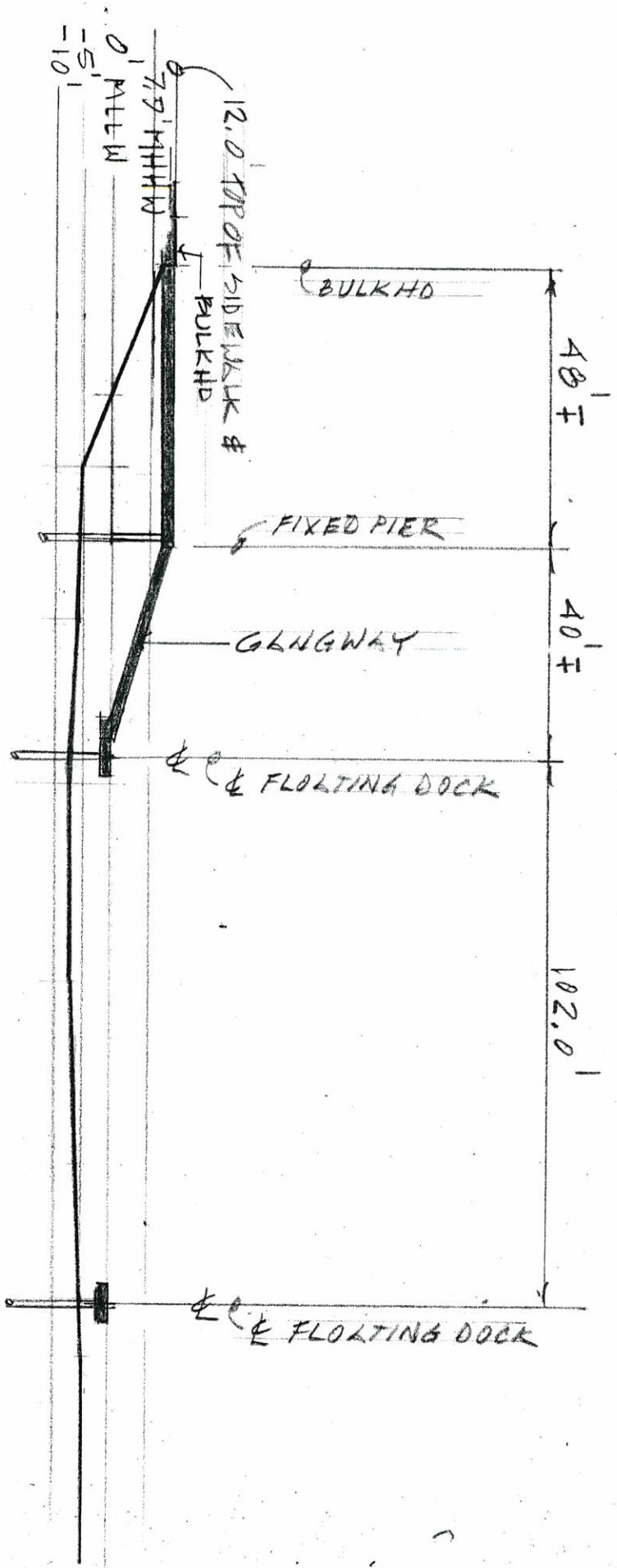

ⓐ

SECTION

SCALE 1" = 30.0'



PORT OF ALSEA

P450F5

**ATTACHMENT C**

**SAMPLE DESIGN/BUILD AGREEMENT**

**Including:**

**EXHIBIT 1— STATE OF OREGON GENERAL CONDITIONS FOR PUBLIC  
IMPROVEMENT CONTRACTS**

**EXHIBIT 2 — GMP AMENDMENT**

**ATTACHMENT C**

**ATTACHMENT C TO RFP # 2018-01  
PORT OF ALSEA  
DESIGN-BUILD AGREEMENT**

**THIS AGREEMENT IS BETWEEN: OWNER: Port of Alsea, Oregon**

**and**

**DESIGN-BUILD CONTRACTOR:**

**Design-Build Contractor's  
Representative is:**

**The Project is: Boat Launch and Marina Construction Project**

**Owner's Representative is: Roxie Cuellar / Port Manager  
Port of Alsea  
365 Port Street  
Waldport, Oregon 97394  
Phone: (541) 563-3872  
Email: [rcuellar@portofalsea.com](mailto:rcuellar@portofalsea.com)**

**Owner's Target GMP: \$2,500,000.00 approximate**

**ATTACHMENT C**



## RECITALS

**WHEREAS**, Owner has property located in Waldport, Oregon, and wishes to have a new boat launch and marina constructed at that location (the "Project"); and,

**WHEREAS**, Owner has developed certain design and performance requirements for the Project, and performance of all necessary design and construction of improvements of new construction in general conformance to the Design-Build Criteria and Scope of Work as part of the Project; and

**WHEREAS**, Owner requires final completion of the Project and full and unrestricted use and occupation of the Facility and grounds by April 15, 2020.

**WHEREAS**, Owner requires a design-build contractor to perform all design and construction work necessary for completion of the Project within the time specified and in accordance with Owner's design and performance requirements and other terms and conditions of the Contract described herein; and

**WHEREAS**, the Design-Build Contractor ("DBC") is prepared to complete such work within the time allotted and under the terms and conditions set forth in the Contract described herein;

**NOW THEREFORE**, in consideration of the mutual promises contained herein, and for other good and valuable consideration described herein, Owner and the DBC (collectively the "Parties") agree as follows:

## AGREEMENT

### ARTICLE 1 GENERAL PROVISIONS

**1.1 Incorporation of Recitals.** The foregoing Recitals are incorporated herein as additional promises, representations and warranties of the Parties as though set forth fully herein.

**1.2 Contract and Contract Documents.** The agreement between the Parties pertaining to the Project (the "Contract") consists of this document entitled, "Design-Build Agreement," and the documents listed in Article 15, together with such Contract amendments and change orders as the Parties may execute hereafter (the "Contract Documents"), all of which are incorporated herein by this reference and made a part hereof for all purposes.

This Contract is intended to reflect the entire understanding of the Parties as to their respective rights and responsibilities concerning the subject matter hereof. There are no understandings, agreements, representations or inducements, oral or written, not incorporated herein.

**1.3 Effective Date.** The Contract shall become effective on the date on which every Party has signed this Design-Build Agreement and the Contract has received all necessary approvals, including approval for legal sufficiency by the Port of Alsea's Legal Counsel (the "Effective Date").

## ATTACHMENT C

**1.4 Defined Terms.** Unless defined in this Section 1.4 or elsewhere in the body of this Design-Build Agreement, capitalized terms in the Contract Documents shall have the meaning set forth in Section A.1 of the General Conditions.

- 1.4.1 "Allowances"** shall mean the allowance amounts shown in the GMP Supporting Documents, together with such further allowances as may be developed by the parties as the Project progresses.
- 1.4.2 "Authority" or "Authorities"** means a government or quasi-governmental unit(s) or political subdivision(s) having jurisdiction over the Project, the Site, or the Work.
- 1.4.3 "Construction Documents"** means the Plans and Specifications describing the requirements for construction of the Project, all of which must comply with the Special Provisions and applicable Legal Requirements.
- 1.4.4 "Construction Services"** means all services identified in Section 2.3 of this Agreement, as more fully described in the Special Provisions.
- 1.4.5 "Consultants"** means individuals performing design and professional services for the Design-Build Contractor on the Project with the approval of Owner.
- 1.4.6 "Contract Price"** means the fixed fee established in Section 5.1 until such time as the GMP Amendment is executed.
- 1.4.7 "Contract Time"** means the amount of time allowed under the Contract to complete the Work or any portion of the Work, calculated from the date of issuance of the Notice to Proceed, and established in the Project Schedule.
- 1.4.8 "Design Build Agreement"** means this document entitled, "Design-Build Agreement," excluding exhibits and material incorporated herein by reference.
- 1.4.9 "Design-Build Contractor" or "DBC"** means the "Contractor" wherever that term is used in the General Conditions.
- 1.4.10 "Design-Build Contractor's Representative" or "DBC Representative"** means the individual identified in writing by the Design-Build Contractor to act on behalf of the Design-Build Contractor for this Project, and to give and receive all notices and communications required under the Contract.
- 1.4.11 "Design Services"** means all services identified in Section 2.2 of this Design Build Agreement, as more fully described in the Special Provisions.

**1.4.12 "Early Work"** shall mean Construction Phase Services authorized by Amendment that the parties agree should be performed in advance of establishment of the GMP. Permissible Early Work shall be limited to: early procurement of materials and supplies, early release of bid or proposal packages for site development and related activities; and any other advance work related to critical

#### ATTACHMENT C

components of the Project for which performance prior to establishment of the GMP will materially affect the critical path schedule of the Project.

- 1.4.13 **"Early Work Amendment"** shall mean an Amendment to this Contract executed by and between the parties to authorize Early Work.
- 1.4.14 **"General Conditions"** means the State of Oregon General Conditions for Public Improvement Contracts (January 1, 2010).
- 1.4.15 **"General Contractor"** means the entity responsible for performing and managing the Construction Services for the Design-Build Contractor.
- 1.4.16 **"GMP Amendment"** means the agreement providing authority to proceed beyond the Schematic Design Phase, based on an agreed to Guaranteed Maximum Price for the creation of a central data center.
- 1.4.17 **"Guaranteed Maximum Price" or "GMP"** means the total price for the construction portion of the Project including 1) the cost to complete construction documents (final design) beyond Schematic design; 2) the expected cost to construct the project; and 3) a contingency amount that the Design-Builder believes should be available to cover changes.
- 1.4.18 **"Legal Requirements" or "Law"** means all applicable federal, State and local laws, codes, ordinances, rules, regulations, orders, permits, and decrees of any government or quasi-governmental unit or political subdivision having jurisdiction over the Project, the Site, or the Work.
- 1.4.19 **"Owner"** means the Port of Alsea.
- 1.4.20 **"Owner's Representative"** has the same meaning as "Owner's Authorized Representative" in Section A.1 of the General Conditions.
- 1.4.21 **"Program Refinement and Schematic Design"** means the preliminary design development to be used as the basis for the establishment of a Guaranteed Maximum Price (GMP) for the Shipyard Improvements and the new Marine Haul-Out Pier.
- 1.4.22 **"Project Site" or "Site"** means the geographical dimensions of the real property within the boundaries of which the Work is to be performed, including designated contiguous staging areas, if any.  
1.4.23 **"Record Documents"** means the as-built Plans, Specifications, product data, samples, shop drawings, Change Orders, and other documents listed in Subsection B.9.1 of the General Conditions, recording changes made during construction.
- 1.4.24 **"Scope of Work"** includes Owner Requirements and Design-Build Criteria, all of which are located in Attachment B to the Request for Proposals, [incorporated herein by reference and made a part hereof for all purposes] when DBC is developing the Design and Construction Documents, they shall conform the Design and Construction Documents with the concepts outlined in the Scope of Work.

#### ATTACHMENT C

- 1.4.25 **"Services"** means all Work required to be performed under the Contract, portions of which are sometimes herein designated as either "Design Services" or "Construction Services."
- 1.4.26 **"Value Engineering"** means alterations in design, materials, methods, finishes, or techniques jointly agreed upon by Owner and the Design-Build Contractor regarding the design or construction of the Project and resulting in cost savings, improved efficiency, or sustainability.
- 1.4.27 **"Work"** shall have the same meaning as the term "Work" in Section A.1 of the General Conditions.

## ARTICLE 2

### **DESIGN AND CONSTRUCTION SERVICES**

**2.1 General Standards for the Work.** Concerning the general standards and terms of performance for all Design Services identified in Section 2.2 of this Design Build Agreement and all Construction Services identified in Section 2.3 of this Design Build Agreement, the Parties agree as follows:

- 2.1.1 All Services constituting the practice of architecture shall be provided by a duly qualified and Oregon-licensed architect either employed by the Design-Build Contractor or hired by the Design-Build Contractor to act as a Consultant. All Services, if any, constituting the practice of engineering shall be provided by a duly-qualified and Oregon-licensed engineer either employed by the Design-Build Contractor or hired by the Design-Build Contractor to act as a Consultant. Because the expertise of the Design-Build Contractor's designated architect and engineer was a material factor in Owner's selection of the Design-Build Contractor, the Design-Build Contractor agrees that it shall not substitute its architect or engineer without Owner's prior consent. The Design-Build Contractor also agrees to support Owner's efforts to create a collaborative and cooperative team between the Design-Build Contractor, its design professionals and Consultants, and Owner's Representative. The Design-Build Contractor, however, shall remain solely liable to Owner for proper completion and timely delivery of all Design Services required under the Contract.
- 2.1.2 The Design-Build Contractor shall provide and perform all Design Services and all Construction Services in good faith and as expeditiously as is consistent with the highest professional skill, care and the orderly progress of the Work.
- 2.1.3 Within seven (7) Days of issuance of Notice to Proceed, the Design-Build Contractor shall submit for Owner's approval the detailed and finalized schedule for the performance of Design Services (the "Design Schedule"), which shall include allowances for periods of time required for Owner's review and for approval of submittals by the Authorities. Once Owner has approved it, the Design-Build Contractor shall not exceed the time limits established in the Design Schedule.

## **ATTACHMENT C**

Within seven (7) Days after Owner approves the Design Schedule, the Design-Build Contractor shall submit for Owner's approval the detailed and finalized schedule for the performance of the Construction Services (the "Construction Schedule). Once Owner has approved it, the Design-Build Contractor shall not exceed the time limits established in the Construction Schedule. (The Design and Construction Schedules are collectively referred to hereafter from time to time as the "Project Schedule"). Both the Design Schedule and the Construction Schedule shall become Contract Documents and shall automatically be incorporated into the Contract upon their approval by Owner.

**2.1.4** The Design-Build Contractor's Representative shall be reasonably available to Owner's Representative for the duration of the Project, and shall have the expertise and experience required to supervise the Work. The Design-Build Contractor's Representative shall communicate regularly with Owner's Representative, and shall have the authority to act on behalf of the Design-Build Contractor in all things relating to performance of the Contract. The Design-Build Contractor's Representative may not be replaced prior to Contract completion without Owner's prior consent.

**2.1.5** Within seven (7) Days of execution of the Contract, Owner and the Design-Builder will hold a pre-design conference to review Owner's requirements, the Contract Documents, and conditions affecting the Work. The conference will also cover the 1) roles of the personnel for the Owner, architects, engineers, Consultants and General Contractor, 2) the procedures to be followed for handling the administrative details, including applications for payment, 3) the procedures to be followed for resolving design questions, scheduling reviews, and communicating approvals, 4) the Project Schedule, 5) confirmation of the scope of services outlined in the Contract Documents, and 6) such other matters as the Parties may wish to address. The location for the pre-design conference will be at a place designated by the Owner.

**2.1.6** Subsequent to the pre-design conference, the Design-Build Contractor shall meet with the Owner at least once each month for the duration of the Contract, and at least once a week during the in-water work period, to participate in progress meetings to discuss: 1) the Project Schedule, 2) design and construction questions, concerns and comments, 3) document submittal status, 4) design, construction and as-built drawings and record documents, and 5) any and all questions that arise. The Design-Build Contractor shall be prepared to discuss the progress of the Work, including the following: 1) whether the Work is proceeding according to the Project Schedule; 2) whether any discrepancies, conflicts, or ambiguities exist among the Contract Documents, or within any particular Contract Document, that require resolution; 3) all safety issues relating to the Project; 4) any other matter that requires resolution to ensure timely and cost-effective completion of the Work. At least four working days prior to the scheduled meeting, the Design-Build Contractor shall submit to Owner a comprehensive list of (a) matters that require resolution, (b) matters that require Owner's approval, and (c) proposed deviations from the Project Schedule, if any, together with reasons or causes therefore, and (d) proposed issues of value engineering or deviation from the established standards of design. **The DBC acknowledges and affirms that in the event the DBC failed to notify Owner prior to the Effective Date of the Contract of discrepancies, conflicts, or ambiguities among the contract Documents, or within any particular Contract Document, that the DBC was or reasonably should have recognized, the DBC shall be responsible**

#### ATTACHMENT C

**for correcting the affected Work to meet Owner's intended requirements at no additional charge, and without additional Contract Time.**

**2.1.7** Owner's review or approval of, and response to, any of the matters presented at Owner/Design-Build Contractor meetings shall not relieve the Design-Build Contractor of its sole responsibility for design or of its obligation to complete the Work within Contract Time and within the interim deadlines established in the Project Schedule, and shall not be construed as relieving the Design-Build Contractor of its complete and exclusive control over the means, methods, sequences and techniques for executing the Work.

**2.2 Design Services.** The Design-Build Contractor agrees to provide all Design Services necessary to enable the Design-Build Contractor to complete the Work in accordance with the Contract Documents and the following standards, and in compliance with the following requirements:

**2.2.1** The Construction Documents:

- (a) The Design-Build Contractor shall provide such additional Specifications as may be necessary that comply with and implement the Special Provisions and Legal Requirements, and shall provide Plans based on the approved Schematic Design Documents and Project Program, which shall set forth all details necessary for construction of the Facility and ancillary structures, and location and installation of utilities on the Project Site, including but not limited to the architectural, structural, mechanical and electrical details. The Design-Build Contractor shall be deemed to have complete control over and charge of acts or omissions of the design professionals, Consultants, the construction contractors, subcontractors, and their agents or employees, and of all other persons performing portions of the Construction Services.
- (b) The Design-Build Contractor shall provide Owner with catalog cuts of all specified materials, product data, shop drawings, samples, manufacturers' test certifications, warranties and such other documentation as may be necessary to confirm compliance of the materials proposed for incorporation into the Project with the Project Specifications set forth in Exhibit C and all Legal Requirements. All materials must comply with the specifications set forth in the Special Provisions. Any deviations from the specified materials and/or manufacturers requires the submission to and approval by the Port.
- (c) After review and approval of the Program Refinement and Schematic Design Documents by Owner and execution of the GMP Amendment, the Design-Build Contractor shall continue with preparation of the Construction Documents, including final Specifications for all Work, and shall incorporate into the Construction Documents the comments and any modifications or changes desired by Owner, and any modifications required for compliance with all Legal Requirements and the Special Provisions. The resulting final Construction Document submittal is to be a complete, fully coordinated, integrated package, without any significant addenda or further clarifications required. All submittals shall be made in accordance with timelines established in the Project Schedule.

#### **ATTACHMENT C**

- (d) The Design-Build Contractor shall provide Owner with an analysis of Legal Requirements, including a code analysis pertaining to the Project, by the date established in the Design Schedule.
- (e) The Design-Build Contractor shall file with the proper Authorities all documents required for their approval, shall, obtain all necessary permits and authorizations, and shall pay for all filing, permit, and other fees.
- (f) The Design-Build Contractor shall provide Owner with copies of Construction Documents as they are completed during construction, as well as the Record Drawings following completion of construction.

**2.2.2** The Design-Build Contractor shall provide professional services, which constitute the practice of architecture and engineering. Such services include the following:

- (a) In consultation with Owner, and in compliance with the Special Provisions, identification of applicable building codes, administrative, and permit processing requirements relevant to the Project.
- (b) In consultation with Owner, evaluate Project Specifications and Owner Requirements and, with appropriate data and graphics, propose a series of improvements, if any, deemed necessary and desirable to satisfy the Project Specifications and Owner Requirements, including space needs, budget, availability and adequacy of utilities, effect of codes and ordinances, safety and energy requirements, handicapped access to all spaces, etc.
- (c) Development of Schematic Design documents for Owner's approval;
- (d) Filing of the required documents for the approval of various Authorities, and payment for all required appeals and plan review fees;
- (e) Submission to Owner the following documents, information and other data:
  - (i) A Design Schedule delineating the schedule for development, submittal, review, and approval of all phases of design development documents and the Construction Documents;
  - (ii) Recommendations by Consultants (structural, mechanical, electrical) of the technical requirements necessary to implement the revised Project Specifications and Owner Requirements and to comply with all Laws;
  - (iii) Preliminary plans, elevations, and other drawings necessary to describe the entire scope of the Project.

Preparation of Plans to fix and describe the size and character of the entire Project as to architectural, structural, mechanical, acoustical, voice data and security systems, and electrical systems, materials and appearances, and such other essentials as may be applicable to the Project or required by or for compliance with governing codes and ordinances and other Laws; and

#### ATTACHMENT C

Assurance that the Project complies with the Americans with Disabilities Act Accessibility Guidelines (ADAAG), latest version, as interpreted and required by Lincoln County during the permit process.

**2.2.3** During development of the Schematic Design Documents and prior to final approval of such documents, The Design-Build Contractor and Owner will collaborate on identifying, evaluating and implementing Value Engineering options that will have the effect of making the Facility and Project more cost-effective, efficient, or sustainable for Owner. Approval of the Schematic Design Documents and finalization of Construction Documents shall not preclude further identification and implementation by the Design-Build Contractor and Owner of additional Value Engineering options during construction.

**2.3 Construction Services—General.** Upon completion and approval of the Design Services applicable to each portion of the Project, the Design-Build Contractor shall perform the Construction Services, including installation of all utilities, described in the Contract Documents. The Design-Build Contractor shall provide all necessary Construction Services, permits, labor, equipment, tools, materials, and incidentals necessary to furnish to Owner a complete boat launch and marina as described herein. The Design-Build Contractor shall perform the Construction Services as follows:

**2.3.1** The Design-Build Contractor shall have complete control over and charge of, and shall be solely responsible for, construction means, methods, techniques, sequences and procedures, and for development and implementation of all safety procedures and a safety program in connection with the Work. The Design-Build Contractor shall be responsible for maintaining the Construction Schedule and for any failure to carry out the Work in accordance with the Contract Documents. The Design-Build Contractor shall be deemed to have complete control over and charge of acts or omissions of the design professionals, Consultants, the construction contractors, subcontractors, and their agents or employees, and of all other persons performing portions of the Construction Services.

**2.3.2** The Design-Build Contractor's responsibility to provide the Construction Services under the Contract commences with the execution of the GMP Amendment and terminates upon the Design-Build Contractor's completion of all obligations set forth in the Contract, including those post-construction responsibilities enumerated at Section K of the General Conditions.

**2.3.3** The Design-Build Contractor shall supervise and administer all construction activities in performance of the Work.

**2.3.4** The Design-Build Contractor's duties, responsibilities and scope of authority as set forth in the Contract cannot be modified except by written Contract amendment executed by the Parties hereto, and including all required State of Oregon approvals, if any.

**2.3.5** Except as may otherwise provided in the Contract Documents, Owner shall direct all its communications to the DBC regarding Construction Services through the DBC's Representative.

#### ATTACHMENT C



- 2.3.6** At its own expense, the DBC shall correct Construction Services which do not conform to the Special Provisions, Construction Documents, or Legal Requirements.
- 2.3.7** The DBC warrants to Owner that materials and equipment incorporated in the Work, and all Work performed in furtherance of the Construction Services will be of good quality, free from faults and defects, and in conformance with the Contract Documents.
- 2.3.8** The DBC shall comply with all Laws relating to the Project, including but not limited to ORS 455.010 through ORS 455.897, as amended, and rules adopted pursuant to those statutes.
- 2.3.9** The DBC shall keep the Project Site free from accumulation of waste materials or rubbish caused by the DBC's operations. At the completion of the Construction Services, the DBC shall remove from and about the Project Site all of the DBC's tools, construction equipment, machinery, surplus materials, waste materials and rubbish.
- 2.3.10** The DBC shall prepare Change Order Requests for Owner's approval and execution, and shall obtain Owner's written approval, in the form of a Change Order, Contract amendment, or Owner's directive for any changes, whether minor or material, in the design or construction of the Facility after the Construction Documents have been approved.
- 2.3.11** The Record Documents shall be delivered to Owner on compact disk and in paper format upon completion of the Construction Services and as a condition to final payment. The DBC acknowledges that it bears sole responsibility to Owner for the accuracy of the information upon which the Record Documents are based.
- 2.3.12** In addition to constituting a "public improvement," the Project construction shall be deemed a "public works" project for the purposes of the prevailing wage rate laws set forth at ORS 279.348 through 279.365. As required by ORS 279.352, all workers in the Project shall be paid not less than the specified minimum hourly rate of wage. A copy of the Oregon Bureau of Labor's current listings applicable to the Project of the prevailing rates of wage for the areas where Work will be performed have been provided to the DBC and are incorporated herein by this reference. The DBC shall pay to the Commissioner of the Bureau of Labor and Industries the fee required by ORS 279.352(2) and ORS 279.375 as more particularly described in Section C of the General Conditions.
- 2.3.13** The DBC shall take reasonable precautions to ensure the safety of, and shall provide reasonable protection to prevent damage, injury or loss to: 1) employees of Owner, employees of the Design-Build Contractor, and other persons who may be present on the Project Site or in a position to be affected by construction activities; 2) the Project Site, and all materials and equipment to be incorporated into the Project; and 3) other property at or adjacent to the Project Site.
- 2.3.14** The DBC shall be liable for injury to persons and damage or loss to property caused by the negligence, gross negligence, recklessness, willful, intentional, or otherwise wrongful acts

**ATTACHMENT C**

or omissions of the Design-Build Contractor, anyone directly or indirectly employed by the DBC, its Consultants, subcontractors, and agents, in performance of both Design and Construction Services under the Contract. This subparagraph shall in no way affect the applicability or diminish the scope of coverage of the bonds and insurance required under Subsections G.2 and G.3 of the General Conditions, or diminish the scope or allocation of responsibility or the indemnity provided for under Subsection G.1 of the General Conditions

**2.3.15** The DBC shall include language in all sub-contracts that the "General Conditions, to the extent not inconsistent with the Design Build Agreement, shall apply to the work of the sub-contractor."

**2.4 Construction Documents.** Upon notification of Owner's approval of the Schematic Design Documents and upon the execution of the GMP Amendment, the DBC, in compliance with the Special Provisions and Legal Requirements, shall prepare the Construction Documents that:

**2.4.1** comply with the Americans with Disabilities Act Accessibility Guidelines (ADAAG) latest version, as interpreted and required by the City of Salem or appropriate local jurisdiction during the permit process;

**2.4.2** comply to the extent practical with the SEED Certification requirements for Class I Buildings as set forth in the Oregon Office of Energy Administrative Rules 330-130-0010 through 330-130-0080;

**2.4.3** comply with parameters of LEED Certification requirements for "Silver" Certification, as set forth in the LEEDTM Certification Program, version 2.1 (November 2002). It is not the intent to certify the facility under the LEED Certification process;

**2.4.4** comply with all applicable Laws; and

**2.4.5** set forth the specific requirements for construction of the Project, including, but not limited to, descriptions of materials and equipment, methods of installation, standards of workmanship and, in the appropriate section of the Specifications, a complete listing of all warranties.

**2.5 Construction Services Responsibility-Specific Construction Services.** Upon execution of the GMP Amendment, the Design-Build Contractor shall:

**2.5.1** attend a pre-construction conference at a site to be determined by Owner;

**2.5.2** provide general administration of the Construction Services;

#### ATTACHMENT C

**2.5.3** upon completion of the Construction Services, and at no additional cost to Owner, update CAD drawings and submit the appropriate compact disks - compatible with AutoCAD 2000, or the current release in use, along with one set of full size bond copy and 1 half-size bond set. Full size copy of drawings will be similar in size to the Construction Documents, but in no event larger than 30" x 40", reflecting significant changes in the Construction Services made during construction based on marked-up prints, drawings and other data obtained by the DBC; and

**2.5.4** perform all other Construction Services otherwise specified in the Contract.

**2.6 Reimbursement for Extra Design Services or Work.** In addition to Construction Services Change Order Work paid for pursuant to other provisions of the Contract, Owner will reimburse the Design-Build Contractor for expenses associated with Design Services under the following circumstances when:

**2.6.1** Owner requests reproduction of documents in excess of the number required herein, reimbursement to be limited to the Design-Build Contractor's reproduction costs only.

**2.6.2** Owner requests Design Services in excess of those identified or necessarily implied in the Contract Documents, but within the scope of the solicitation. Provided, however, Owner and the Design-Build Contractor must execute a Contract Amendment and obtain all necessary State approvals before such Work shall be performed, or any payments made.

### **ARTICLE 3** **RELATIONSHIP AND ROLES OF THE PARTIES**

**3.1 Independent Contractor.** The Design-Build Contractor is an independent contractor and not an officer, employee, or agent of Owner as those terms are used in ORS 30.265.

**3.2 Owner's Representative.** Owner's Representative is Owner's exclusive representative to the DBC with respect to the Contract, unless Owner designates another representative and notifies the DBC in writing of that designation. All communications from Owner to the DBC will be issued or made through Owner's Representative. Owner's Representative shall have the authority to establish procedures, consistent with the Contract, to be followed by the DBC and to call periodic conferences to be attended by the DBC throughout the term of the Contract. Owner's Representative shall have no authority to amend the Contract, however, outside the change order process that is set forth in Section D.1 of the General Conditions.

**3.3 Design-Build Contractor's Representative.** The DBC's Representative shall be the DBC's exclusive representative to Owner with respect to the Contract, unless the DBC designates another representative and notifies Owner in writing of that designation. All communications from the DBC to Owner will be issued or made through the DBC's Representative. The DBC's Representative shall have the authority to execute change orders and Contract Amendments on behalf of the DBC.

### **ATTACHMENT C**

**3.4 Design-Build Contractor's Key Personnel.** The DBC's personnel, as identified in their Proposal, shall be considered unique, key personnel and shall not be replaced during the Project without the written permission of Owner, which shall not be unreasonably withheld. If the DBC intends to substitute key personnel, a request must be given to Owner at least 30 Days prior to the intended time of substitution. When Owner has approved replacements, the DBC shall provide a transition period of at least 15 working days during which the original and replacement personnel shall be working on the Project concurrently.

**3.5 The Design-Build Contractor's Consultants.** The DBC's Consultants identified in DBC's Proposal shall be considered unique, and shall not be replaced during the Project without the written permission of Owner. If the DBC intends to substitute a Consultant, it must submit a request to Owner at least 30 Days prior to the intended time of substitution, and include the identity of the proposed replacement. Owner shall be deemed to have consented to the employment of such Consultant unless Owner objects to the employment of such Consultant in writing within such 30-Day period; *provided that* if Owner subsequently discovers information which leads Owner to reasonably believe a Consultant selected by the DBC and approved by Owner is unqualified to perform the Work, the DBC shall replace such Consultant upon the request of Owner.

**3.6 The DBC's Architect.** If the DBC intends to substitute its architect, the DBC must submit a written request to Owner at least 30 Days prior to the intended date of substitution. Upon Owner's approval, the original and replacement architects shall work concurrently during a transition period of at least 10 working days. Owner has sole discretion to approve subsequent replacements.

#### ARTICLE 4

#### **DATE OF COMMENCEMENT AND COMPLETION OF THE DESIGN SERVICES AND THE CONSTRUCTION SERVICES**

**4.1 Commencement of Services.** The Design-Build Contractor shall commence the Work contemplated by the Contract upon complete execution of the Design Build Agreement and receipt of Notice to Proceed.

**4.2 Completion of Project.** The DBC will complete the Schematic Design Documents and Construction Documents (the permit set) on or before the dates set therefore in the Project Schedule approved by Owner. The DBC shall achieve Substantial Completion and Final Completion of the Construction Services by no later than the dates set therefore in the Project Schedule approved by Owner.

**4.3 Notice to Proceed. Owner will** issue its Notice to Proceed at time of Contract execution. Owner will authorize the DBC's commencement of the Construction Services following the execution of the GMP Amendment and completion of Construction Documents sufficient to enable construction based thereon.

**4.4 Time is of the Essence.** All time limits stated in the Contract Documents are of the essence. No provision of the Contract shall preclude recovery of actual damages for delay by either party. Actual damages incurred by Owner in the event of late completion include but are not limited to: costs of

#### **ATTACHMENT C**

temporary facilities for Owner and Owner's lessees, professional and legal fees and charges, and administrative expenses.

**4.5 Time for Performance.** This Design Build Agreement shall take effect on the Effective Date and the DBC shall perform the Contract through Project Completion, in accordance with the Project Schedule.

**4.6 Punch List.** Owner's Representative will issue a complete "punch list" of incomplete or defective items to the DBC within ten (10) Days after the Design-Build Contractor's issuance of the Notice of Substantial Completion. The punch list will include a requirement that the DBC deliver one complete set of "as built drawings" and other Record Documents to Owner, if such documents have not been provided with the Notice of Substantial Completion. The DBC shall complete all punch-list items within 21 Days of receipt of the punch list.

## **ARTICLE 5**

### **CONTRACT SUM AND GMP**

**5.1 Contract Sum.** If a GMP Amendment or Early Work Amendment is executed, Owner shall pay the DBC, as payment for the Work, the "Contract Sum" which shall equal the sum of the Schematic Design Fee, and the actual Cost of the Work, but not exceeding the GMP.

The GMP shall be determined as detailed in Article 1.4.17. **and** as described in Article 5.4. The "Cost of the Work" is defined in Article 7. Costs in excess of the GMP shall be paid by the DBC without reimbursement from Owner. Changes to the GMP shall only be authorized by Amendment or Change Order that includes any necessary Port of Alsea approvals, including any approvals by the Port's Legal Counsel.

**5.2 Program Refinement and Schematic Design Fee.** The Program Refinement and Schematic Design Fee shall be payable to DBC on a cost reimbursement basis up to a maximum sum of \$XXXXXX which shall cover constructability review, value engineering, cost estimating, identification of cost effective energy conservation measures, program refinement, schematic design development, development of GMP, and all other services necessary to establish the GMP, as described in this Article 5. If the DBC's costs for provision of Program Refinement and Schematic Design Phase Services exceed the maximum Program Refinement and Schematic Design Fee, the DBC shall pay such additional cost without reimbursement. The DBC shall not be entitled to any DBC Fee upon the Program Refinement and Schematic Design Fee. Owner shall pay the Program Refinement and Schematic Design Fee on a cost-reimbursement basis with each application for payment up to the time the GMP Amendment is executed. Except to the extent the parties may expressly agree to the contrary in the GMP Amendment, no Program Refinement and Schematic Design Fee or other fee, compensation or reimbursement shall be payable to DBC after execution of the GMP Amendment.

### **5.3 Determination of GMP.**

**5.3.1** The DBC shall deliver to Owner a proposed GMP and GMP Supporting Documents at the completion of the Schematic Design Phase. If any actual subcontract Offers are available at the time the GMP is being established, the DBC shall use those subcontract Offers in establishing the GMP.

## **ATTACHMENT C**

**5.3.2** As the Plans and Specifications may not be developed to the stage of biddable design documents at the time the GMP proposal is prepared, the DBC shall provide, in the GMP, for further development of the Plans and Specifications by the design team that is consistent with the Contract Documents and reasonably inferable there from. Such further development shall not include such things as changes in scope, systems, kinds and quality of materials, finishes or equipment, all of which, if required, shall be incorporated by Change Order or Amendment with a corresponding GMP adjustment.

**5.4.3** The DBC shall include with its GMP proposal a written statement of its basis (the "GMP Supporting Documents"), which shall include:

- (a) A list of the Plans and Specifications, including all addenda thereto and the conditions of the Contract, which were used in preparation of the GMP proposal.
- (b) A list of allowances and a statement of their basis.
- (c) A list of the clarifications and assumptions made by the DBC in the preparation of the GMP proposal to supplement the information contained in the Plans and Specifications.
- (d) The proposed GMP, including a statement of the estimated cost organized by trade categories, allowances, contingency, and other items and the associated fees that comprise the GMP.
- (e) The Date of Substantial Completion upon which the proposed GMP is based, and a schedule of the Construction Documents issuance dates upon which the date of Substantial Completion is based.

**5.4.4** The DBC shall meet with the Owner to review the GMP proposal and the written statement of its basis. If the Owner discovers any inconsistencies or inaccuracies in the information presented, they shall promptly notify the DBC, who shall make appropriate adjustments to the GMP proposal, its basis or both.

**5.4.5** Prior to the Owner's acceptance of the DBC's GMP proposal and the execution of the GMP Amendment, the DBC shall not incur any cost to be reimbursed as part of the Cost of the Work, except as specifically provided in any Early Work Amendment.

**5.4.6** The Owner shall authorize and cause the DBC to revise the Plans and Specifications to the extent necessary to reflect the agreed-upon assumptions and clarifications contained in the GMP Amendment. Such revised Plans and Specifications shall be prepared by the DBC in accordance with schedules agreed to by the Owner and DBC. The DBC shall promptly notify the Owner if such revised Plans and Specifications are inconsistent with the agreed-upon assumptions and clarifications.

**5.4.7** The GMP shall include in the Cost of the Work only those taxes which are enacted at the time the GMP is established.

**5.4.8** The estimated Cost of the Work shall include the DBC's contingency, a sum established by the DBC for the DBC's exclusive use to cover additional development of Plans and Specifications and unforeseen costs which are properly reimbursable as Cost of the Work but which are not the basis for a Change Order.

**5.4.9** The DBC shall work with the Owner to identify and confirm components and systems not specifically shown but required for a complete, fully functional Project.

#### ATTACHMENT C

**5.4.10** Notwithstanding the level of detail represented in the GMP Supporting Documents, the DBC shall represent and warrant, at the time that it submits the GMP, that the GMP includes the entire cost of all components and systems required for complete, fully functional facilities.

**5.4.11** In developing the GMP, the DBC shall include and identify such contingencies within the GMP as may be necessary to pay for unforeseen elements that are required for a complete, fully functional facility.

**5.4 Failure to Furnish an Acceptable GMP.** If the DBC does not furnish a GMP acceptable to Owner that approximates the Preliminary Target GMP, or if Owner determines at any time in its sole discretion that the Parties will fail to reach a timely agreement on a GMP acceptable to Owner, Owner may terminate this Contract without liability, and the DBC shall not receive additional compensation beyond the Program Refinement and Schematic Design Fee under this Contract and sums due under any Early Work Amendment. Termination under this provision shall proceed under Section J.5 of the General Conditions as a termination for Owner's convenience. The DBC further agrees that Owner shall not be liable for any damages whether actual, consequential or otherwise for termination of the Contract under this provision.

**5.5 Acceptance of GMP.** Upon acceptance of the GMP by Owner, the parties shall execute a GMP Amendment.

**5.6 Owner Savings.** If the final Cost of the Work (the Contract Sum as defined in Article 5.1), is less than the GMP, the savings shall be shared equally between the Owner and the DBC.

**5.7 Reallocating Projected Cost Under-runs after Bid (Offer) Buyout.** As soon as possible after the primary Subcontractors are selected for the work DBC shall review projected costs and provide the Owner with a buy-out status report showing any projected cost under-runs, reconciling accepted offers and other reasonably anticipated costs, to the cost estimate used by the DBC to establish the GMP. The DBC shall include with its report any underlying documentation requested by Owner used to develop or support such report. The DBC shall also consider the reduced risk associated with known subcontracting costs, and the impact that reduced risk has on the amount of the DBC's Contingency. The parties shall negotiate in good faith to execute a Change Order transferring an appropriate portion of any projected cost under-runs to an Owner-controlled contingency fund to be held within the GMP to pay for additional costs arising from (a) any Owner-directed or approved change to the Work, (b) schedule changes that would otherwise entitle the DBC to an increase in the GMP, (c) Allowance items after exhaustion of all Allowances, (d) selection by Owner of more expensive alternates than those used for calculation of the GMP, (e) Owner selection of substitutions that increase the Cost of the Work, or (f) any other costs which otherwise would entitle the DBC to an increase in the GMP pursuant to Article 6.2. Any transfer of projected cost under-runs from the DBC's contingency to the Owner-controlled contingency fund will not affect the DBC's obligation to complete the Project within the GMP.

## **ARTICLE 6** **CHANGES IN THE WORK**

**6.1 Price Adjustments.** Adjustments to the estimated Cost of the Work required by changes in the Work shall be determined by any of the methods listed in Section D of the General Conditions, except that, unless the adjustment is based upon fixed pricing or unit pricing:

### **ATTACHMENT C**

- 6.1.1 The overhead and profit markup for the DBC shall be limited to the DBC Fee adjustment, if any, permitted under Article 5.3.1 of this Contract;
- 6.1.2 The increase or decrease in the estimated Cost of the Work, other than for subcontract work, shall be calculated pursuant to Articles 7 and 8 of this Contract, instead of being based on the DBC's Direct Costs as defined in the General Conditions; and
- 6.1.3 In calculating adjustments to subcontracts, unless the parties agree otherwise, the change shall be limited to the Subcontractor's Direct Costs plus the supplemental mark-up provided in Section D of the General Conditions, and shall not be modified by Articles 7 and 8 of this Contract.

**6.2 Adjustments to GMP.** Adjustments to the GMP after execution of the GMP Amendment may be made only (i) in the event of Scope Changes or (ii) as otherwise expressly provided in this Contract, and then only in accordance with the following procedure:

- 6.2.1 The DBC shall review subsequent iterations of the Plans and Specifications as they are prepared to determine whether, in the opinion of the DBC, they result in a Scope Change so that it can be determined if an adjustment to the GMP is warranted.
- 6.2.2 Changes to the GMP shall be initiated by written notice by one party to the other ("GMP Change Request"). The DBC shall deliver any such GMP Change Request to the Owner's Authorized Representative promptly after becoming aware of any Scope Change if, in the DBC's opinion, it constitutes grounds for adjustment of the GMP. Any GMP Change Request shall include a proposal as to the appropriate GMP adjustment with respect to the Scope Change at issue.
- 6.2.3 The DBC shall submit its GMP Change Requests as soon as possible, and the DBC shall not be entitled to claim a GMP increase unless the DBC submitted a GMP Change Request to Owner's Authorized Representative within the earlier of (a) 30 Days after the DBC has received the information constituting the basis for the claim, or (b) as to Work not yet bid or proposed, prior to submission of solicitations for such Work and as to Work already solicited, prior to commencement of the portion of the Work for which the DBC intends to claim a Scope Change; or (c) in any event, prior to the DBC's signing of a Change Order for the Scope Change.
- 6.2.4 Owner may, at any time, submit a GMP Change Request requesting a reduction of the GMP, which shall include Owner's basis for such request, which may include, for example, reduction of the DBC's Contingency after further development of the Plans and Specifications that form the basis for the original GMP Amendment, or unused Allowances.
- 6.2.5 The DBC shall work with the Owner to reconcile all differences in its GMP Change Request within seven days from the date of submission of the GMP Change Request. "Reconciled" means that the DBC and the Owner have verified that their assumptions about the various categories are the same, and that identifies the reason for differences in the GMP Change Request and the Owner's position. The DBC shall submit the Reconciled GMP

#### ATTACHMENT C



Change Request to Owner, which submission shall be a condition to any DBC claim for a GMP increase.

- 6.2.6 If the Reconciled GMP Change Request is not acceptable to Owner, the DBC agrees to work with the Owner to provide a GMP Change Request that is acceptable to Owner.
- 6.2.7 The DBC agrees to make all records, calculations, drawings and similar items relating to GMP Change Request available to Owner and to allow Owner access and opportunity to view such documents at DBC's offices. Upon Owner's reasonable notice, the DBC shall deliver two copies of such documents to Owner at any regular meeting or at the Site.
- 6.2.8 GMP increases, if any, shall not exceed the increased Cost of the Work arising from the Scope Change (whether based on agreed fixed pricing, or the estimated Cost of the Work increase based on cost-reimbursable pricing), reconciled in accordance with the above provisions, as arising from the incident justifying the GMP increase, plus or minus the Design Build Fee applicable to such change in the Cost of the Work.
- 6.2.9 Except as provided in this Article 6.2, adjustments to the GMP shall be reconciled in accordance with Section D of the General Conditions.

**6.3 Execution by Owner.** Only the duly authorized personnel of the Owner have authority to execute Change Orders or Amendments.

**ARTICLE 7**  
**COST OF THE WORK**  
**(To be reimbursed)**

**7.1 Cost of the Work.** The term "Cost of the Work" shall mean the following costs. The Cost of the Work shall include only those items necessarily and reasonably incurred by the DBC in the proper performance of the Work and specifically identified in this Article 7, and only to the extent that they are directly related to the Project.

**7.2 Labor Costs.**

- 7.2.1 Wages of construction workers directly employed by the DBC to perform the construction of the Work at the site.
- 7.2.2 Wages and salaries of the DBC's supervisory and administrative personnel (i) stationed at the site, or (ii) engaged at factories, workshops or on the road, in expediting the production or transportation of materials or equipment required for the Work with Owner, or otherwise engaged and off the site when specifically related to the Project, in each case under this clause; and (iii) only with Owner's prior written approval, and only for that portion of their time directly required for the Work.
- 7.2.3 Fringe benefit costs paid or incurred by the DBC for taxes, insurance, contributions, assessments and benefits required by law or collective bargaining contracts and, for personnel not covered by such contracts, customary benefits such as sick leave, medical and health benefits, holidays, vacations and pensions, provided such costs are based on wages and salaries included in the Cost of the Work under Articles 7.2.1 and 7.2.2.

**ATTACHMENT C**

### **7.3 Subcontract Costs.**

- 7.3.1** No amount paid by or payable to any Subcontractor other than the fixed or cost reimbursement price of its subcontract shall be included in the Cost of the Work, unless otherwise approved in writing by Owner.

### **7.4 Costs of Materials and Equipment Incorporated in the Work or Stored On Site.**

- 7.4.1** Costs, including transportation, of materials and equipment incorporated or to be incorporated in the completed Work.
- 7.4.2** Costs of materials in excess of those actually installed, but required to provide reasonable allowance for waste and for spoilage. Unused excess materials, if any, shall be delivered to Owner at the completion of the Work or, at Owner's option, shall be sold by the DBC. Any sale shall be commercially reasonable and the DBC shall provide accounting for such a sale within 15 Days of the transaction. Net amounts realized, if any, from such sales shall be credited to Owner as a deduction from the Cost of the Work.

### **7.5 Costs of Miscellaneous Equipment and Other Items; Equipment Rental Charges.**

- 7.5.1** Costs, including transportation, installation, maintenance, dismantling and removal, of materials, supplies, temporary facilities, machinery, equipment, and hand tools not customarily owned by the construction workers, which are provided by the DBC at the site and fully consumed in the performance of the Work; and cost less salvage value on such items if not fully consumed, whether sold to others or retained by the DBC; provided that Owner at Owner's option may require that the DBC deliver to Owner (at no charge) at the end of the Project any of such items procured for this Project. Cost for items previously used by the DBC shall mean fair market value. The DBC shall charge no additional administrative or other mark-up for purchased items. The DBC shall document all small tools purchased for the Project via invoices in monthly billing, and shall document the disposition of small tools which have an individual price that exceeds \$100. A copy of such disposition log shall accompany the payment application whenever these items are included in the application.
- 7.5.2** Rental charges for temporary facilities, machinery, equipment and hand tools not customarily owned by the construction workers, which are provided by the DBC at the site, whether rented from the DBC or Others, and costs of transportation, installation, minor repairs and replacements, dismantling and removal thereof. Rates and quantities of equipment rented shall be according to industry standards, shall not exceed 100% of the rental rates published from time to time by the American Association of Equipment dealers in effect at the time of rental, shall not exceed acquisition costs, and for individual items exceeding \$500.00, will be subject to Owner's prior approval. The DBC shall deliver to Owner a list of published rates from time to time at Owner's request. For all items rented or leased, the DBC shall charge Owner only the rental charge incurred by the DBC with no additional administrative or other mark-up. The DBC shall make efforts and use its best skills and judgment to procure equipment in the most expeditious and economical manner consistent with the interest of the Owner. Efforts shall include, but not be limited to, providing Owner with a rent/buy analysis so that Owner may elect for DBC to procure the item in lieu of rental if the facility at issue is expected to be rented for six months or

## **ATTACHMENT C**

longer. Such rent/buy analysis shall include, where available, a leasing rate commensurate with the expected term of rental of the facility at issue. Inclusions to and exclusions from rental rates will be made in accordance with American Association of Equipment Dealer standards.

- 7.5.3 Costs of removal of debris from the site.
- 7.5.4 Cost of long-distance telephone calls, postage and parcel delivery charges, telephone service at the site and reasonable petty cash expenses of the site office, which are solely for the benefit of the Work.
- 7.5.5 That portion of the travel and subsistence expenses of the DBC's personnel determined by Owner to be reasonable and necessary incurred while traveling in discharge of duties connected with the Work. DBC's main office staff travel shall not be reimbursed unless approved in advance by Owner

#### **7.6 Other Costs.**

- 7.6.1 That portion of premiums for insurance directly attributable to this Contract, including deductible for builders all/risk insurance (but excluding premiums for professional liability/errors & omissions insurance related to the Project design, as well as comprehensive general liability, automobile and worker's compensation coverage that is not Project specific), and payment and performance bonds as required by Section G of the General Conditions (but excluding premiums for Subcontractor bonds unless authorized by Owner).
- 7.6.2 Sales, use or similar excise taxes imposed by a governmental authority which are directly related to the Work and for which the DBC is liable.
- 7.6.3 Fees and assessments for the building permit and for other permits, licenses and inspections for which the DBC is required by the Contract Documents to pay.
- 7.6.4 Other costs incurred in the performance of the Work if and to the extent approved in advance in writing by Owner.

**7.7 Repairs to Damaged, Defective or Nonconforming Work.** The Cost of the Work shall also include costs which are incurred by the DBC in taking action to prevent threatened damage, injury or loss in case of an emergency affecting the safety of persons and property.

### **ARTICLE 8** **COSTS EXCLUDED FROM THE WORK** **(Not To Be Reimbursed)**

**8.1 Costs Excluded from Cost of Work.** The following shall not be included in the Cost of the Work:

- 8.1.1 Salaries and other compensation of the DBC's personnel stationed at the DBC's principal office or offices other than the site office except as allowed under Articles 7.2.2 and 7.2.3.

#### **ATTACHMENT C**

- 8.1.2 Expenses of the DBC's principal office and offices other than the site office.
- 8.1.3 Any overhead and general expenses, except as may be expressly included in Article 7.
- 8.1.4 The DBC's capital expenses, including interest on the DBC's capital employed for the Work.
- 8.1.5 Rental cost of machinery and equipment, except as provided in Article 7.5.2
- 8.1.6 Any cost associated with the Project not specifically and expressly described in Article 7.
- 8.1.7 Costs due to the fault or negligence of the DBC, Subcontractors, suppliers, anyone directly or indirectly employed by any of them, or for whose acts any of them may be liable.
- 8.1.8 The cost of correction of any repair work, nonconforming or defective work, or warranty work.
- 8.1.9 Merit, safety, or other incentive payments, bonuses or awards, or any expenses in connection therewith.
- 8.1.10 Fines and penalties.
- 8.1.11 Except for Early Work, the cost of Schematic Design Phase Services.
- 8.1.12 Any costs in excess of the GMP.

**ARTICLE 9**  
**DISCOUNTS, REBATES AND REFUNDS**

**9.1 Discounts, Rebates and Refunds.** Cash discounts obtained on payments made by the DBC shall accrue to Owner. Trade discounts, rebates, refunds and net amounts received from sales of surplus materials and equipment shall accrue to Owner, and the DBC shall make provisions so that they can be secured.

**9.2 Amounts Credited to Owner.** Amounts which accrue to Owner in accordance with the provisions of Article 9.1 shall be credited to Owner as a deduction from the Cost of the Work.

**ARTICLE 10**  
**INSURANCE PROVISIONS**

During the term of the Contract the DBC is required, pursuant to Section G.3 of the General Conditions, to maintain certain insurance in full force, at its own expense, from companies licensed to do business in Oregon. Certain subsections of Section G.3 are modified as follows:

**ATTACHMENT C**

**10.1 Employers' Liability.** The DBC shall carry employers' liability insurance coverage with combined single limit per occurrence of not less than \$500,000, and annual aggregate limits of not less than \$1,000,000.

**10.2 General Liability.** The DBC shall secure Commercial General Liability insurance with a combined single limit of not less than \$1,000,000 each occurrence, \$4,000,000 annual aggregate, for bodily injury and property damage. It shall include personal injury coverage, Products and Completed Operations, and contractual liability coverage for the indemnity provided under the Contract.

**10.3 Builder's All-Risk/Direct Risk Of Physical Damage.** During the term of the Contract, the DBC shall maintain in force, at its own expense, Builder's Risk insurance on an all risk/direct risk of physical damage form, including earthquake and flood, for an amount equal to the full amount payable under the Contract. Any deductible shall not exceed \$50,000 each loss, except the earthquake and flood deductible shall not exceed 2 percent of each loss or \$50,000, whichever is more. The policy shall be endorsed/amended to include the Port of Alsea as additional insureds, as their interests may appear (the DBC shall provide Owner with a copy of any endorsement to the policy to confirm this requirement.)

**10.4 Automobile Liability.** The DBC shall secure Automobile Liability insurance with a combined single limit of not less than \$1,000,000 per occurrence, \$4,000,000 annual aggregate for bodily injury and property damage, including coverage for all owned, hired, or non-owned vehicles, as applicable. This coverage may be written in combination with the Commercial General Liability Insurance.

**10.5 Professional Liability/Errors & Omissions.** The DBC shall provide Owner with proof of coverage for Professional Liability/Errors & Omissions insurance covering any damages caused by any negligent error, omission, or any act in furtherance of Design Services for the Project, whether performed by an architect or engineer under the Contract. The policy may be either a practice based policy or a policy pertaining to the specific Project, but the policy must cover the Port of Alsea as "owner." Professional Liability insurance to be provided shall have a combined single limit of not less than \$1,000,000 per occurrence/\$1,000,000 annual aggregate. The Design-Build Contractor shall execute such documents and agreements and obtain such insurer consents, endorsements, and acknowledgments as shall be necessary to provide Owner with direct access to the coverage afforded under each professional liability/errors & omissions policy covering the Design Services to be performed pursuant to the Contract.

**10.6 Certificate of Insurance.** Prior to the signature by Owner to this Design Build Agreement, the DBC shall furnish to Owner Certificates of Insurance as evidence of the insurance coverage required under the Contract. The certificate(s) shall provide that the insurance policies have been endorsed/amended so that the insurance company or companies shall give a 30-Day notice (without reservation) to Owner if the applicable policy is canceled or materially changed, or if the aggregate limits have been reduced. The certificate(s) shall state specifically that the insurance is provided for this Project and Contract.

**10.7 Additional Insureds.** The Certificates of Insurance, except for Workers' Compensation and Professional Liability/Errors & Omissions, shall provide that the policies have been endorsed/amended so that the Port of Alsea, and employees are additional Insureds with respect to the DBC's Services/Work to be provided under the Contract. The DBC shall provide Owner with copies of all policy endorsements/amendments confirming the Port of Alsea's status as

#### ATTACHMENT C

additional Insureds, as required by the Contract.

## ARTICLE 11

### **OWNERSHIP AND USE OF WORK PRODUCT**

**Ownership of Contract Documents.** Copies of Plans, Specifications, reports, or other materials required elsewhere in the Contract to be delivered to Owner, including without limitation materials identified as "instruments of service" in any agreement between the DBC and any of its Consultants or Subcontractors ("Work Product") shall be the exclusive property of Owner. Owner and the DBC intend that such Work Product be deemed "work made for hire," for which Owner shall be deemed the author. If for any reason such Work Products are not deemed "work made for hire," the DBC hereby irrevocably assigns to Owner all of its right, title and interest in and to any and all of such Work Products, whether arising from copyright, patent, trademark, trade secret, or any other state or federal intellectual property law or doctrine. The DBC shall ensure and shall confirm to Owner that the DBC's agreements with its Consultants, Subcontractors, employees and agents conform to the requirements of this section, and agrees further to execute such further documents and instruments as Owner may reasonably request in order to fully vest such rights in Owner. The DBC forever waives, for itself, its Consultants, Subcontractors, employees and agents, any and all rights relating to such Work Product, including without limitation, any and all rights arising under 17 USC 106A or any other rights of identification of authorship or rights of approval, restriction or limitation on use of subsequent modifications.

**11.2 Right of Use.** The DBC, despite other conditions of this Article, shall have the right to use such Work Product in its brochures or other literature that it may employ for its sales and in addition, unless specifically otherwise prohibited, the DBC may use standard line drawings, specifications and calculations on other unrelated projects.

## ARTICLE 12

### **ACCOUNTING RECORDS**

The DBC shall keep full and detailed accounts and exercise such controls as may be necessary for proper financial management under the Contract; the accounting and control systems shall be satisfactory to Owner. Owner and Owner's representatives, shall be afforded reasonable and regular access to the DBC's records, books, correspondence, instructions, drawings, receipts, subcontracts, purchase orders, vouchers, memoranda and other data relating to the Contract, and the DBC shall preserve these for a period of six (6) years after final payment, or until the resolution of any dispute, if any, involving the Contract, or for such longer period as may be required by law.

## ARTICLE 13

### **PAYMENTS**

**13.1 Schedule of Payments.** Owner shall make payments to the DBC according to the provisions of Section E of the General Conditions on the dates listed below:

### **ATTACHMENT C**

**13.1.1** Design Services. On the fifth (5<sup>th</sup>) day of each month following execution of the Design Build Agreement, the DBC shall submit its application for payment to Owner for Design Services performed during the prior month. Subject to the terms and conditions of Section E of the General Conditions, Owner will make payment within 30 Days of receipt of an application for payment. Provided, however, no retainage shall be withheld from payments for Design Services.

**13.1.2** Construction Services. On the fifth (5<sup>th</sup>) day of each month following commencement of Construction Services, the DBC shall submit its application for payment to Owner for construction services performed during the prior month in compliance with the terms and conditions of Section E of the General Conditions. Owner will make payment to the DBC, subject to the terms and conditions of Section E of the General Conditions, within 30 Days of receipt of each application for payment.

**13.1.3** Retainage. Owner shall withhold retainage in the amount of 5% from all payments relating to Construction Services in accordance with the provisions of Section E.5 of the General Conditions.

**ARTICLE 14**  
**TERMINATION OR SUSPENSION**

Section J of the General Conditions governs Contract termination and duties of the Parties in the event of Contract termination, modified only to the extent set forth below:

**14.1 Owner's Termination.**

**14.1.1** For Convenience. Owner may terminate the Contract without penalty for convenience pursuant to Section J.5 of the General Conditions; payment in such case shall be governed by Section E of the General Conditions. However, the amount to be paid to the DBC under the General Conditions shall not in any case exceed the Contract Price.

**14.1.2** Funding/Authority. Owner may terminate the Contract, in whole or in part, immediately upon notice to the DBC, or at such later date as Owner may establish in such notice, upon:

- (a) Owner's failure to receive funding, or appropriations, limitations or other expenditure authority at levels sufficient to pay for the DBC's Design Services or Construction Services;
- (b) Modification or interpretation of Federal or state laws, regulations or guidelines in such a way that either the Design Services or Construction Services performed under the Contract are prohibited or Owner is prohibited from paying for such Design Services or Construction Services from the planned funding source;
- (c) DBC may terminate the Contract for cause in the event Owner has failed to make timely payments of amounts not in dispute in accordance with Section E

**ATTACHMENT C**

of the General Conditions, following notice as provided below and 10 Days' opportunity to cure.

**14.1.3** For Cause. Owner may terminate the Contract, in whole or in part, immediately upon notice to the DBC, or at such later date as Owner may establish in such notice, in the event:

- (a) the DBC or its Consultants no longer hold any license or certificate that is required to perform the Work;
- (b) the DBC commits any material breach or default of any covenant, warranty, obligation or agreement under the Contract, fails to perform the Design Services or Construction Services under the Contract within the time specified herein or any extension thereof, or so fails to perform the Design Services or Construction Services as to endanger the DBC's performance under the Contract in accordance with its terms, and such breach, default or failure is not cured within 10 business days after delivery of Owner's notice, or such longer period of cure as Owner may specify in such notice.

**14.1.4** Owner reasonably believes that sufficient funds are anticipated to pay all amounts due hereunder and hereby covenants and agrees that it will use its best efforts to obtain and properly request and pursue funds from which payments hereunder may be made, including making provisions for such payments to the extent necessary in the budget submitted for the purpose of obtaining funds and using its best efforts to have such budget approved. It is Owner's intention to make all payments due hereunder if funds are legally available therefore and in that regard Owner represents and warrants to the Design-Build Contractor that the Contract is important to Owner's efficient and economic operation. If, despite the above, Owner is not allotted sufficient funds for the next succeeding fiscal period by appropriation, appropriation limitation, grant, or other funds source lawfully available to it for such purposes to continue the Project and make payments hereunder, Owner may terminate the Contract, by notice to the DBC without penalty, effective at the end of the current fiscal period for which funds have been allocated and if not so terminated Owner will remain fully obligated for all amounts owing hereunder. Such termination shall not constitute an event of default under any other provision of the Contract, but Owner shall be obligated to pay all charges incurred through the end of such fiscal period. Owner shall give the DBC notice of such non-availability of funds within thirty (30) Days after it received notice of such non-availability.

## **14.2 Termination of Contract by the Design-Build Contractor.**

**14.2.1** In Event of Suspension of the Work. The DBC may terminate the Contract for cause if the Work is stopped for 120 Days through no act or fault of the DBC or a Consultant, Sub-subcontractor or their agents or employees or any other persons performing portions of the Work under contract with the DBC, for any of the following reasons:

### **ATTACHMENT C**



- (a) Issuance of an order of a court or other public authority having jurisdiction;(b) An act of government, such as a declaration of national emergency, making material unavailable;

**14.3 Payment upon termination.** Payment upon termination shall be governed by Section E of the General Conditions.

- 14.3.1** Notwithstanding the foregoing, neither Party shall be entitled to consequential damages, exemplary damages, compensation for lost opportunity, or lost profits.

**ARTICLE 15**  
**ENUMERATION OF CONTRACT DOCUMENTS**  
**AND ORDER OF PRECEDENCE**

The Contract Documents are listed below and are intended to be complementary. However, in the event of conflicts or discrepancies among the Contract Documents, interpretation will be based on the descending order of precedence in which the Contract Documents are listed.

1. Contract Amendments, with those of a later date having precedence over those of an earlier date.
2. Change Orders, with those of a later date having precedence over those of an earlier date.
3. This Design Build Agreement, minus all exhibits and material incorporated herein by reference
4. Construction Plans and Specifications
5. Permits and Orders issued by any government or quasi-governmental unit or political subdivision having jurisdiction over the Project, the Site, or the Work
6. Project Schedule
7. Construction Plans and Specifications
8. General Conditions
9. Remaining documents incorporated into the Contract by reference.

The General Conditions, to the extent not inconsistent with this Design Build Agreement, shall also apply to the work of all subcontractors.

**ARTICLE 16**  
**PROJECT SCHEDULE**

The Design Schedule and the Construction Schedule (collectively the "Project Schedule") shall establish the deadlines for performance and milestones for completion of Design and Construction Services under the Contract and shall generally be in conformance with the requirements of the Preliminary Design/Build Scope of Work shown in **Attachment B** to the RFP.

**ARTICLE 17**  
**OWNER'S INSURANCE**

Owner is self-insured under ORS 278.425 and this insurance shall cover Owner's operations and activities at the Project Site.

**ATTACHMENT C**

**ARTICLE 18**  
**MISCELLANEOUS PROVISIONS**

**18.1 Governing Law; Jurisdiction; Venue.** This Contract shall be governed by and construed in accordance with the laws of the State of Oregon without regard to principles of conflicts of law. Any claim, action, suit or proceeding (collectively "Claim") between Owner and the DBC that arises from or relates to the Contract shall be brought and conducted solely and exclusively within the Circuit Court of Marion County for the State of Oregon; *provided, however*, if a Claim must be brought in a federal forum, then it shall be brought and conducted solely and exclusively within the United States District Court for the District of Oregon. In no event shall this Section be construed as a waiver by the State of Oregon of any form of defense or immunity, whether based on sovereign immunity, governmental immunity, immunity based on the Eleventh Amendment to the United States Constitution or otherwise. DBC, BY EXECUTION OF THIS DESIGN BUILD AGREEMENT, CONSENTS TO THE PERSONAL JURISDICTION OF SUCH COURTS.

**18.2 Notices.** Except as otherwise expressly provided in the Contract, any notices to be given hereunder shall be given in writing by personal delivery, facsimile, or mailing the same, postage prepaid, to the DBC or Owner at the addresses or numbers as either party may hereafter indicate pursuant to this Section. Any notice so addressed and mailed shall be deemed to be given five (5) calendar days after the date of mailing. Any notice delivered by facsimile shall be deemed to be given when receipt of the transmission is generated by the transmitting machine. To be effective against Owner, such facsimile transmission must be confirmed by telephone notice to Owner's Representative for the Project. Any notice by personal delivery shall be deemed to be given when actually delivered. Regular, day-to-day communications may be transmitted through one of the methods set forth above, in person, by e-mail, or by other similar electronic transmission.

**18.3 Disclosure of Tax Identification Number.** The DBC shall provide its federal tax ID number to Owner. This number is required pursuant to ORS 305.385. The Tax Identification Number provided pursuant to this authority will be used for the administration of state, federal and local tax laws.

**18.4 Severability.** The Parties agree that if any term or provision of the Contract is declared by a court of competent jurisdiction to be illegal, in conflict with any law, or otherwise invalid, the validity of the remaining terms and provisions shall not be affected, and the rights and obligations of the Parties shall be construed and enforced as if the Contract did not contain the particular term or provision held to be invalid.

**18.5 Waiver.** The failure of Owner to enforce any provision of the Contract shall not constitute a waiver by Owner of that provision, or any other provision of the Contract.

**18.6 Media Contacts; Confidentiality.** The DBC shall provide no news release, press release, or any other statement to a member of the news media regarding this Project, without Owner's prior written authorization. Furthermore, except in the case where Owner specifically authorizes

**ATTACHMENT C**

disclosure of Owner's confidential information in writing, the DBC shall maintain the confidentiality of Owner's information pertaining to the Project, unless withholding such information would violate the law, create the risk of significant harm to the public or prevent the DBC from establishing a claim or defense in an adjudicatory proceeding. The DBC shall require all of its Subcontractors to maintain a similar level of confidentiality of Owner's information.

**18.7 Conflict of Interest.** Except with Owner's prior written consent, the DBC shall not engage in any activity, or accept any employment, interest or contribution that would, or would reasonably appear, to compromise the DBC's professional judgment with respect to this Project, including, without limitation, concurrent employment on any project in direct competition with the Project.

**18.8 Merger Clause.** THE CONTRACT CONSTITUTES THE ENTIRE AGREEMENT BETWEEN THE PARTIES ON THE SUBJECT MATTER ADDRESSED THEREIN. THE TERMS OF THE CONTRACT CAN NOT BE WAIVED, ALTERED, MODIFIED, SUPPLEMENTED, OR AMENDED, IN ANY MANNER WHATSOEVER, EXCEPT BY WRITTEN INSTRUMENT SIGNED BY THE PARTIES AND CONTAINING ALL REQUIRED STATE OF OREGON APPROVALS. ANY SUCH WAIVER, ALTERATION, MODIFICATION, SUPPLEMENTATION, OR AMENDMENT, IF MADE, SHALL BE EFFECTIVE ONLY IN THE SPECIFIC INSTANCE AND FOR THE SPECIFIC PURPOSE GIVEN. THERE ARE NO UNDERSTANDINGS, AGREEMENTS, OR REPRESENTATIONS, ORAL OR WRITTEN, REGARDING THE CONTRACT EXCEPT AS CONTAINED, INCORPORATED OR REFERENCED THEREIN. DESIGN-BUILDER, BY THE SIGNATURE BELOW OF ITS AUTHORIZED REPRESENTATIVE, HEREBY ACKNOWLEDGES THAT IT HAS READ THE CONTRACT, UNDERSTANDS IT, AND AGREES TO BE BOUND BY ITS TERMS AND CONDITIONS. THE CONTRACT MAY BE EXECUTED IN SEVERAL COUNTERPARTS, EACH OF WHICH SHALL BE AN ORIGINAL, AND ALL OF WHICH SHALL CONSTITUTE BUT ONE AND THE SAME INSTRUMENT.

**ATTACHMENT C**

**THIS DESIGN BUILD AGREEMENT** is executed in two original copies, of which one is to be delivered to the Design-Build Contractor, and one to Owner. By signature on this Design Build Agreement, the undersigned hereby certifies under penalty of perjury that the undersigned is authorized to act on behalf of the Design-Build Contractor and has authority and knowledge regarding the payment of taxes, and that the Design-Build Contractor is, to the best of the undersigned's knowledge, not in violation of any Oregon Tax Laws. For purposes of this certification, "Oregon Tax Laws" means a state tax imposed by ORS 401.792 to 401-816 and ORS chapters 118, 314, 316, 317, 318, 320, 321 and 323; and the elderly rental assistance program under ORS 310.630 to 310.706; and local taxes administered by the Department of Revenue under ORS 305.620

IN WITNESS WHEREOF, the parties have executed this Design Build Agreement and the Contract shall be effective as of the last date written below.

**DESIGN BUILD CONTRACTOR:**

Name of Construction Contractor Firm: \_\_\_\_\_  
Federal Tax I.D. #: \_\_\_\_\_  
Construction Contractor's Oregon License Registration No.:

By: \_\_\_\_\_ Date: \_\_\_\_\_

Title:

**OWNER:**

The Port of Alsea

By: \_\_\_\_\_ Date: \_\_\_\_\_

Title:

Approved as to Legal  
Sufficiency

By: \_\_\_\_\_ Date: \_\_\_\_\_

Exhibits:       Exhibit 1 - State of Oregon General Conditions for Public Improvement Contracts  
                  Exhibit 2 - GMP Amendment template

**ATTACHMENT C**

**Exhibit 1**  
**STATE OF OREGON GENERAL CONDITIONS FOR**  
**PUBLIC IMPROVEMENT CONTRACTS**

## EXHIBIT 6

### State of Oregon General Conditions for Public Improvement Contracts JANUARY 1, 2010



## STATE OF OREGON

### GENERAL CONDITIONS FOR PUBLIC IMPROVEMENT CONTRACTS

## NOTICE TO STATE AGENCIES AND PUBLIC IMPROVEMENT CONTRACTORS

### January 1, 2010 Edition

The attached **State of Oregon General Conditions for Public Improvement Contracts (“General Conditions”)** applies to all designated public improvement contracts. These provisions are intended for use within an agency’s own procurement documents and contracts, and do not contain the certifications and other forms required by particular public contracting agencies.

Changes to the General Conditions (including any additions, deletions or substitutions) should only be made by Supplemental General Conditions, unless the General Conditions are specifically modified in the Public Improvement Agreement (which has a higher order of precedence under Section A.3 of the General Conditions). The text of these General Conditions should not otherwise be altered. For guidance, see the separate document entitled **“Guidelines for Development of Supplemental General Conditions”**. Electronic copies of the General Conditions, the Guidelines for Development of Supplemental General Conditions and a form for the Supplemental General Conditions are available at the Oregon Department of Administrative Services web site at:

[http://www.oregon.gov/DAS/SSD/SPO/purchasing-links.shtml#Public\\_Improvement](http://www.oregon.gov/DAS/SSD/SPO/purchasing-links.shtml#Public_Improvement)

**NOTE: THE FOLLOWING GENERAL CONDITIONS HAVE BEEN REVIEWED AS TO FORM BY THE OREGON DEPARTMENT OF JUSTICE. THE LEGAL SUFFICIENCY AND APPROVAL REQUIREMENTS OF ORS 291.047 ARE STILL APPLICABLE FOR INDIVIDUAL PROCUREMENTS OF STATE AGENCIES, UNLESS AN EXEMPTION HAS BEEN GRANTED PURSUANT TO THAT STATUTE AND ADMINISTRATIVE RULES AT OAR CHAPTER 137, DIVISION 45.**

### EXHIBIT 1, ATTACHMENT C – GENERAL CONDITIONS

**STATE OF OREGON  
GENERAL CONDITIONS FOR PUBLIC IMPROVEMENT CONTRACTS  
JANUARY 1, 2010**

TABLE OF SECTIONS

**SECTION A**  
**GENERAL PROVISIONS**

- A.1 DEFINITION OF TERMS
- A.2 SCOPE OF WORK
- A.3 INTERPRETATION OF CONTRACT DOCUMENTS
- A.4 EXAMINATION OF PLANS, SPECIFICATIONS,  
AND SITE
- A.5 INDEPENDENT CONTRACTOR STATUS
- A.6 RETIREMENT SYSTEM STATUS AND TAXES
- A.7 GOVERNMENT EMPLOYMENT STATUS

**SECTION B**  
**ADMINISTRATION OF THE CONTRACT**

- B.1 OWNER'S ADMINISTRATION OF THE CONTRACT
- B.2 CONTRACTOR'S MEANS AND METHODS
- B.3 MATERIALS AND WORKMANSHIP
- B.4 PERMITS
- B.5 COMPLIANCE WITH GOVERNMENT LAWS AND REGULATIONS
- B.6 SUPERINTENDENCE
- B.7 INSPECTION
- B.8 SEVERABILITY
- B.9 ACCESS TO RECORDS
- B.10 WAIVER
- B.11 SUBCONTRACTS AND ASSIGNMENT
- B.12 SUCCESSORS IN INTEREST
- B.13 OWNER'S RIGHT TO DO WORK
- B.14 OTHER CONTRACTS
- B.15 GOVERNING LAW
- B.16 LITIGATION
- B.17 ALLOWANCES
- B.18 SUBMITTALS, SHOP DRAWINGS, PRODUCT DATA AND SAMPLES
- B.19 SUBSTITUTIONS
- B.20 USE OF PLANS AND SPECIFICATIONS
- B.21 FUNDS AVAILABLE AND AUTHORIZED
- B.22 NO THIRD PARTY BENEFICIARIES

**SECTION C**  
**WAGES AND LABOR**

- C.1 MINIMUM WAGES RATES ON PUBLIC WORKS
- C.2 PAYROLL CERTIFICATION; ADDITIONAL RETAINAGE; FEE REQUIREMENTS
- C.3 PROMPT PAYMENT AND CONTRACT CONDITIONS

**EXHIBIT 1, ATTACHMENT C – GENERAL CONDITIONS**

- C.4 PAYMENT FOR MEDICAL CARE
- C.5 HOURS OF LABOR

**SECTION D**  
**CHANGES IN THE WORK**

- D.1 CHANGES IN THE WORK
- D.2 DELAYS
- D.3 CLAIMS REVIEW PROCESS

**SECTION E**  
**PAYMENTS**

- E.1 SCHEDULE OF VALUES
- E.2 APPLICATIONS FOR PAYMENT
- E.3 PAYROLL CERTIFICATION REQUIREMENT
- E.4 DUAL PAYMENT SOURCES
- E.5 RETAINAGE
- E.6 FINAL PAYMENT

**SECTION F**  
**JOB SITE CONDITIONS**

- F.1 USE OF PREMISES
- F.2 PROTECTION OF WORKERS, PROPERTY  
AND THE PUBLIC
- F.3 CUTTING AND PATCHING
- F.4 CLEANING UP
- F.5 ENVIRONMENTAL CONTAMINATION
- F.6 ENVIRONMENTAL CLEAN-UP
- F.7 FORCE MAJEURE

**SECTION G**  
**INDEMNITY, BONDING AND INSURANCE**

- G.1 RESPONSIBILITY FOR DAMAGES/INDEMNITY
- G.2 PERFORMANCE AND PAYMENT SECURITY; PUBLIC WORKS BOND
- G.3 INSURANCE

**SECTION H**  
**SCHEDULE OF WORK**

- H.1 CONTRACT PERIOD
- H.2 SCHEDULE
- H.3 PARTIAL OCCUPANCY OR USE

**SECTION I**  
**CORRECTION OF WORK**

- I.1 CORRECTIONS OF WORK BEFORE FINAL  
PAYMENT

**EXHIBIT 1, ATTACHMENT C – GENERAL CONDITIONS**



I.2 WARRANTY WORK

**SECTION J**

**SUSPENSION AND/OR TERMINATION OF THE WORK**

- J.1 OWNER'S RIGHT TO SUSPEND THE WORK
- J.2 CONTRACTOR'S RESPONSIBILITIES
- J.3 COMPENSATION FOR SUSPENSION
- J.4 OWNER'S RIGHT TO TERMINATE CONTRACT
- J.5 TERMINATION FOR CONVENIENCE
- J.6 ACTION UPON TERMINATION

**EXHIBIT 1, ATTACHMENT C – GENERAL CONDITIONS**

**STATE OF OREGON  
GENERAL CONDITIONS FOR PUBLIC IMPROVEMENT CONTRACTS**

**SECTION A  
GENERAL PROVISIONS**

**A.1 DEFINITION OF TERMS**

In the Contract Documents the following terms shall be as defined below:

**ARCHITECT/ENGINEER**, means the Person appointed by the Owner to make drawings and specifications and, to provide contract administration of the Work contemplated by the Contract to the extent provided herein or by supplemental instruction of Owner (under which Owner may delegate responsibilities of the Owner's Authorized Representative to the Architect/Engineer), in accordance with ORS Chapter 671 (Architects) or ORS Chapter 672 (Engineers) and administrative rules adopted thereunder.

**CHANGE ORDER**, means a written order issued by the Owner's Authorized Representative to the Contractor requiring a change in the Work within the general scope of the Contract Documents, issued under the changes provisions of Section D.1 in administering the Contract, including Owner's written change directives as well as changes reflected in a writing executed by the parties to this Contract and, if applicable, establishing a Contract Price or Contract Time adjustment for the changed Work.

**CLAIM**, means a demand by Contractor pursuant to Section D.3 for review of the denial of Contractor's initial request for an adjustment of Contract terms, payment of money, extension of Contract Time or other relief, submitted in accordance with the requirements and within the time limits established for review of Claims in these General Conditions.

**CONTRACT**, means the written agreement between the Owner and the Contractor comprised of the Contract Documents which describe the Work to be done and the obligations between the parties.

**CONTRACT DOCUMENTS**, means the Solicitation Document and addenda thereto, the State of Oregon Public Improvement Agreement Form, General Conditions, Supplemental General Conditions, if any, the accepted Offer, Plans, Specifications, amendments and Change Orders.

**CONTRACT PERIOD**, as set forth in the Contract Documents, means the total period of time beginning with the issuance of the Notice to Proceed and concluding upon Final Completion.

**CONTRACT PRICE**, means the total of the awarded Offer amount, as increased or decreased by the price of approved alternates and Change Orders.

**CONTRACT TIME**, means any incremental period of time allowed under the Contract to complete any portion of the Work as reflected in the project schedule.

**CONTRACTOR**, means the Person awarded the Contract for the Work contemplated.

**DAYS**, are calendar days, including weekdays, weekends and holidays, unless otherwise specified.

**DIRECT COSTS**, means, unless otherwise provided in the Contract Documents, the cost of materials, including sales tax, cost of delivery; cost of labor, including social security, old age and unemployment insurance, and fringe benefits required by agreement or custom; worker's compensation insurance; project specific insurance (including, without limitation, Builder's Risk Insurance and Builder's Risk Installation Floater); bond premiums, rental cost of equipment, and machinery required for execution of the work; and the additional costs of field personnel directly attributable to the Work.

**EXHIBIT 1, ATTACHMENT C – GENERAL CONDITIONS**

**FINAL COMPLETION**, means the final completion of all requirements under the Contract, including Contract Closeout as described in Section K but excluding Warranty Work as described in Section I.2, and the final payment and release of all retainage, if any, released.

**FORCE MAJEURE**, means an act, event or occurrence caused by fire, riot, war, acts of God, nature, sovereign, or public enemy, strikes, freight embargoes or any other act, event or occurrence that is beyond the control of the party to this Contract who is asserting Force Majeure.

**NOTICE TO PROCEED**, means the official written notice from the Owner stating that the Contractor is to proceed with the Work defined in the Contract Documents. Notwithstanding the Notice to Proceed, Contractor shall not be authorized to proceed with the Work until all initial Contract requirements, including the Contract, performance bond and payment bond, and certificates of insurance, have been fully executed and submitted to Owner in a suitable form.

**OFFER**, means a bid in connection with an invitation to bid and a proposal in connection with a request for proposals.

**OFFEROR**, means a bidder in connection with an invitation to bid and a proposer in connection with a request for proposals.

**OVERHEAD**, means those items which may be included in the Contractor's markup (general and administrative expense and profit) and that shall not be charged as Direct Cost of the Work, including without limitation such Overhead expenses as wages or salary of personnel above the level of foreman (i.e., superintendents and project managers), and expenses of Contractor's offices at the job site (e.g. job trailer) including expenses of personnel staffing the job site office, and Commercial General Liability Insurance and Automobile Liability Insurance.

**OWNER**, means the State of Oregon acting by and through the governmental entity identified in the Solicitation Document.

**OWNER'S AUTHORIZED REPRESENTATIVE**, means those individuals identified in writing by the Owner to act on behalf of the Owner for this project. Owner may elect, by written notice to Contractor, to delegate certain duties of the Owner's Authorized Representative to more than one party, including without limitation, to an Architect/Engineer. However, nothing in these General Conditions is intended to abrogate the separate design professional responsibilities of Architects under ORS Chapter 671 or of Engineers under ORS Chapter 672.

**PERSON**, means an entity doing business as a sole proprietorship, a partnership, a joint venture, a corporation, a limited liability company or partnership, or any other entity possessing the legal capacity to contract.

**PLANS**, means the drawings which show the location, type, dimensions, and details of the Work to be done under the Contract.

**PUNCHLIST**, means the list of Work yet to be completed or deficiencies which need to be corrected in order to achieve Final Completion of the Contract.

**RECORD DOCUMENT**, means the as-built Plans, Specifications, testing and inspection records, product data, samples, manufacturer and distributor/supplier warranties evidencing transfer to Owner, operational and maintenance manuals, shop drawings, Change Orders, correspondence, certificate(s) of occupancy, and other documents listed in Subsection B.9.1 of these General Conditions, recording all Services performed.

**SOLICITATION DOCUMENT**, means an invitation to bid or request for proposal or request for quotes.

**SPECIFICATION**, means any description of the physical or functional characteristics of the Work, or of the nature of a supply, service or construction item. Specifications may include a description of any requirement for inspecting, testing or preparing a supply, service or construction item for delivery and the quantities or qualities of materials to be furnished under the Contract. Specifications generally will state the results or products to be

#### **EXHIBIT 1, ATTACHMENT C – GENERAL CONDITIONS**

obtained and may, on occasion, describe the method and manner of doing the work to be performed. Specifications may be incorporated by reference and/or may be attached to the Contract.

**SUBCONTRACTOR**, means a Person having a direct contract with the Contractor, or another Subcontractor, to perform one or more items of the Work.

**SUBSTANTIAL COMPLETION**, means the date when the Owner accepts in writing the construction, alteration or repair of the improvement to real property or any designated portion thereof as having reached that state of completion when it may be used or occupied for its intended purpose. Substantial Completion of facilities with operating systems occurs only after thirty (30) continuous Days of successful, trouble-free operation of the operating systems as provided in Section K.4.2.

**SUBSTITUTIONS**, means items that in function, performance, reliability, quality, and general configuration are the same or better than the product(s) specified. Approval of any substitute item shall be solely determined by the Owner's Authorized Representative. The decision of the Owner's Authorized Representative is final.

**SUPPLEMENTAL GENERAL CONDITIONS**, means those conditions that remove from, add to, or modify these General Conditions. Supplemental General Conditions may be included in the Solicitation Document or may be a separate attachment to the Contract.

**WORK**, means the furnishing of all materials, equipment, labor, transportation, services and incidentals necessary to successfully complete any individual item or the entire Contract and the carrying out of duties and obligations imposed by the Contract Documents.

## **A.2 SCOPE OF WORK**

The Work contemplated under this Contract includes all labor, materials, transportation, equipment and services for, and incidental to, the completion of all construction work in connection with the project described in the Contract Documents. The Contractor shall perform all Work necessary so that the project can be legally occupied and fully used for the intended use as set forth in the Contract Documents.

## **A.3 INTERPRETATION OF CONTRACT DOCUMENTS**

A.3.1 Unless otherwise specifically defined in the Contract Documents, words which have well-known technical meanings or construction industry meanings are used in the Contract Documents in accordance with such recognized meanings. Contract Documents are intended to be complementary. Whatever is called for in one, is interpreted to be called for in all. However, in the event of conflicts or discrepancies among the Contract Documents, interpretations will be based on the following descending order of precedence:

1. Contract amendments and Change Orders, with those of later date having precedence over those of an earlier date;
2. The Supplemental General Conditions;
3. The State of Oregon Public Improvement Agreement Form;
4. The General Conditions
5. The Plans and Specifications
6. The Solicitation Document and any addenda thereto;
7. The accepted Offer.

### **EXHIBIT 1, ATTACHMENT C – GENERAL CONDITIONS**

A.3.2 In the case of an inconsistency between Plans and Specifications or within either document not clarified by addendum, the better quality or greater quantity of Work shall be provided in accordance with the Owner or Owner's Authorized Representative's interpretation in writing.

A.3.3 If the Contractor finds discrepancies in, or omissions from the Contract Documents, or if the Contractor is in doubt as to their meaning, the Contractor shall at once notify the Owner or Owner's Authorized Representative. Matters concerning performance under, and interpretation of requirements of, the Contract Documents will be decided by the Owner's Authorized Representative, who may delegate that duty in some instances to the Architect/Engineer. Responses to Contractor's requests for interpretation of Contract Documents will be made in writing by Owner's Authorized Representative (or the Architect/Engineer) within any time limits agreed upon or otherwise with reasonable promptness. Interpretations and decisions of the Owner's Authorized Representative (or Architect/Engineer) will be consistent with the intent of and reasonably inferable from the Contract Documents. Contractor shall not proceed without direction in writing from the Owner's Authorized Representative (or Architect/Engineer).

A.3.4 References to standard specifications, manuals, codes of any technical society, organization or association, to the laws or regulations of any governmental authority, whether such reference be specific or by implication, shall mean the latest standard specification, manual, code, laws or regulations in effect in the jurisdiction where the project is occurring on the first published date of the Solicitation Document, except as may be otherwise specifically stated.

#### **A.4 EXAMINATION OF PLANS, SPECIFICATIONS, AND SITE**

A.4.1 It is understood that the Contractor, before submitting an Offer, has made a careful examination of the Contract Documents; has become fully informed as to the quality and quantity of materials and the character of the Work required; and has made a careful examination of the location and conditions of the Work and the sources of supply for materials. The Owner will in no case be responsible for any loss or for any unanticipated costs that may be suffered by the Contractor as a result of the Contractor's failure to acquire full information in advance in regard to all conditions pertaining to the Work. No oral agreement or conversation with any officer, agent, or personnel of the Owner, or with the Architect/Engineer either before or after the execution of this Contract, shall affect or modify any of the terms or obligations herein contained.

A.4.2 Should the Plans or Specifications fail to particularly describe the materials, kind of goods, or details of construction of any aspect of the Work, Contractor shall have the duty to make inquiry of the Owner and Architect/Engineer as to what is required prior to performance of the Work. Absent Specifications to the contrary, the materials or processes that would normally be used to produce first quality finished Work shall be considered a part of the Contract requirements.

A.4.3 Any design errors or omissions noted by the Contractor shall be reported promptly to the Owner's Authorized Representative, including without limitation, any nonconformity with applicable laws, statutes, ordinances, building codes, rules and regulations.

A.4.4 If the Contractor believes that additional cost or Contract Time is involved because of clarifications or instructions issued by the Owner's Authorized Representative (or Architect/Engineer) in response to the Contractor's notices or requests for information, the Contractor must submit a written request to the Owner's Authorized Representative, setting forth the nature and specific extent of the request, including all time and cost impacts against the Contract as soon as possible, but no later than thirty (30) Days after receipt by Contractor of the clarifications or instructions issued. If the Owner's Authorized Representative denies Contractor's request for additional compensation, additional Contract Time, or other relief that Contractor believes results from the clarifications or instructions, the Contractor may proceed to file a Claim under Section D.3, Claims Review Process. If the Contractor fails to perform the obligations of Sections A.4.1 to A.4.3, the Contractor shall pay such costs and damages to the Owner as would have been avoided if the Contractor had performed such obligations.

#### **A.5 INDEPENDENT CONTRACTOR STATUS**

### **EXHIBIT 1, ATTACHMENT C – GENERAL CONDITIONS**

The service or services to be performed under this Contract are those of an independent contractor as defined in ORS 670.600. Contractor represents and warrants that it is not an officer, employee or agent of the Owner.

#### **A.6 RETIREMENT SYSTEM STATUS AND TAXES**

Contractor represents and warrants that it is not a contributing member of the Public Employees' Retirement System and will be responsible for any federal or state taxes applicable to payment received under this Contract. Contractor will not be eligible for any benefits from these Contract payments of federal Social Security, employment insurance, workers' compensation or the Public Employees' Retirement System, except as a self-employed individual. Unless the Contractor is subject to backup withholding, Owner will not withhold from such payments any amount(s) to cover Contractor's federal or state tax obligations.

#### **A.7 GOVERNMENT EMPLOYMENT STATUS**

A.7.1 If this payment is to be charged against federal funds, Contractor represents and warrants that it is not currently employed by the Federal Government. This does not preclude the Contractor from holding another contract with the Federal Government.

A.7.2 Contractor represents and warrants that Contractor is not an employee of the State of Oregon for purposes of performing Work under this Contract.

### **SECTION B**

#### ***ADMINISTRATION OF THE CONTRACT***

#### **B.1 OWNER'S ADMINISTRATION OF THE CONTRACT**

B.1.1 The Owner's Authorized Representative will provide administration of the Contract as described in the Contract Documents (1) during construction (2) until final payment is due and (3) during the one-year period for correction of Work. The Owner's Authorized Representative will act on behalf of the Owner to the extent provided in the Contract Documents, unless modified in writing in accordance with other provisions of the Contract. In performing these tasks, the Owner's Authorized Representative may rely on the Architect/Engineer or other consultants to perform some or all of these tasks.

B.1.2 The Owner's Authorized Representative will visit the site at intervals appropriate to the stage of the Contractor's operations (1) to become generally familiar with and to keep the Owner informed about the progress and quality of the portion of the Work completed, (2) to endeavor to guard the Owner against defects and deficiencies in the Work, and (3) to determine in general if Work is being performed in a manner indicating that the Work, when fully completed, will be in accordance with the Contract Documents. The Owner's Authorized Representative will not make exhaustive or continuous on-site inspections to check the quality or quantity of the Work. The Owner's Authorized Representative will neither have control over or charge of, nor be responsible for the construction means, methods, techniques, sequences or procedures, or for the safety precautions and programs in connection with the Work.

B.1.3 Except as otherwise provided in the Contract Documents or when direct communications have been specifically authorized, the Owner and Contractor shall endeavor to communicate with each other through the Owner's Authorized Representative or designee about matters arising out of or relating to the Contract. Communications by and with the Architect/Engineer's consultants shall be through the Architect/Engineer. Communications by and with Subcontractors and material suppliers shall be through the Contractor. Communications by and with separate contractors shall be through the Owner's Authorized Representative.

B.1.4 Based upon the Architect/Engineer's evaluations of the Contractor's Application for Payment, or unless otherwise stipulated by the Owner's Authorized Representative, the Architect/Engineer will review and certify the amounts due the Contractor and will issue Certificates for Payment in such amounts.

#### **EXHIBIT 1, ATTACHMENT C – GENERAL CONDITIONS**

## **B.2 CONTRACTOR'S MEANS AND METHODS; MITIGATION OF IMPACTS**

B.2.1 The Contractor shall supervise and direct the Work, using the Contractor's best skill and attention. The Contractor shall be solely responsible for and have control over construction means, methods, techniques, sequences and procedures and for coordinating all portions of the Work under the Contract, unless the Contract Documents give other specific instructions concerning these matters. If the Contract Documents give specific instructions concerning construction means, methods, techniques, sequences or procedures, the Contractor shall evaluate the jobsite safety thereof and, except as stated below, shall be fully and solely responsible for the jobsite safety of such means, methods, techniques, sequences or procedures.

B.2.2 The Contractor is responsible to protect and maintain the Work during the course of construction and to mitigate any adverse impacts to the project, including those caused by authorized changes, which may affect cost, schedule, or quality.

B.2.3 The Contractor is responsible for the actions of all its personnel, laborers, suppliers, and Subcontractors on the project. The Contractor shall enforce strict discipline and good order among Contractor's employees and other persons carrying out the Work. The Contractor shall not permit employment of persons who are unfit or unskilled for the tasks assigned to them.

## **B.3 MATERIALS AND WORKMANSHIP**

B.3.1 The intent of the Contract Documents is to provide for the construction and completion in every detail of the Work described. All Work shall be performed in a professional manner and unless the means or methods of performing a task are specified elsewhere in the Contract Documents, Contractor shall employ methods that are generally accepted and used by the industry, in accordance with industry standards.

B.3.2 The Contractor is responsible to perform the Work as required by the Contract Documents. Defective Work shall be corrected at the Contractor's expense.

B.3.3 Work done and materials furnished shall be subject to inspection and/or observation and testing by the Owner's Authorized Representative to determine if they conform to the Contract Documents. Inspection of the Work by the Owner's Authorized Representative does not relieve the Contractor of responsibility for the Work in accordance with the Contract Documents.

B.3.4 Contractor shall furnish adequate facilities, as required, for the Owner's Authorized Representative to have safe access to the Work including without limitation walkways, railings, ladders, tunnels, and platforms. Producers, suppliers, and fabricators shall also provide proper facilities and access to their facilities.

B.3.5 The Contractor shall furnish Samples of materials for testing by the Owner's Authorized Representative and include the cost of the Samples in the Contract Price.

## **B.4 PERMITS**

Contractor shall obtain and pay for all necessary permits and licenses, except for those specifically excluded in the Supplemental General Conditions, for the construction of the Work, for temporary obstructions, enclosures, opening of streets for pipes, walls, utilities, environmental Work, etc., as required for the project. Contractor shall be responsible for all violations of the law, in connection with the construction or caused by obstructing streets, sidewalks or otherwise. Contractor shall give all requisite notices to public authorities. The Contractor shall pay all royalties and license fees. The Contractor shall defend all suits or claims for infringement of any patent or other proprietary rights and save harmless and blameless from loss, on account thereof, the State of Oregon, and its departments, divisions, members and employees.

## **B.5 COMPLIANCE WITH GOVERNMENT LAWS AND REGULATIONS**

### **EXHIBIT 1, ATTACHMENT C – GENERAL CONDITIONS**

B.5.1 Contractor shall comply with all federal, state and local laws, codes, regulations and ordinances applicable to the Work and the Contract. Failure to comply with such requirements shall constitute a breach of Contract and shall be grounds for Contract termination. Without limiting the generality of the foregoing, Contractor expressly agrees to comply with the following as applicable: i) Title VI and VII of Civil Rights Act of 1964, as amended; (ii) Section 503 and 504 of the Rehabilitation Act of 1973, as amended; (iii) the Health Insurance Portability and Accountability Act of 1996; (iv) the Americans with Disabilities Act of 1990, as amended; (v) ORS Chapter 659A; as amended (vi) all regulations and administrative rules established pursuant to the foregoing laws; and (vii) all other applicable requirements of federal and state civil rights and rehabilitation statutes, rules and regulations. Owner's performance under the Contract is conditioned upon Contractor's compliance with the provisions of ORS 279C.505, 279C.510, 279C.515, 279C.520, and 279C.530, which are incorporated by reference herein.

B.5.2 Contractor shall comply with all applicable requirements of federal and state civil rights and rehabilitation statutes, rules and regulations; and

(a) Contractor shall not discriminate against Disadvantaged, Minority, Women or Emerging Small Business enterprises, as those terms are defined in ORS 200.005, or a business enterprise that is owned or controlled by or that employs a disabled veteran, as that term is defined in ORS 408.225, in the awarding of subcontracts (ORS 279A.110).

(b) Contractor shall maintain, in current and valid form, all licenses and certificates required by law, regulation, or this Contract when performing the Work.

B.5.3 Unless contrary to federal law, Contractor shall certify that it shall not accept a bid from Subcontractors to perform Work as described in ORS 701.005 under this Contract unless such Subcontractors are registered with the Construction Contractors Board in accordance with ORS 701.035 to 701.055 at the time they submit their bids to the Contractor.

B.5.4 Unless contrary to federal law, Contractor shall certify that each landscape contractor, as defined in ORS 671.520(2), performing Work under this Contract holds a valid landscape contractor's license issued pursuant to ORS 671.560.

B.5.5 The following notice is applicable to Contractors who perform excavation Work. ATTENTION: Oregon law requires you to follow rules adopted by the Oregon Utility Notification Center. Those rules are set forth in OAR 952-001-0010 through OAR 952-001-0090. You may obtain copies of the rules by calling the center at (503)232-1987.

B.5.6 Failure to comply with any or all of the requirements of B.5.1 through B.5.5 shall be a breach of Contract and constitute grounds for Contract termination. Damages or costs resulting from such noncompliance shall be the responsibility of Contractor.

## **B.6 SUPERINTENDENCE**

Contractor shall keep on the site, during the progress of the Work, a competent superintendent and any necessary assistants who shall be satisfactory to the Owner and who shall represent the Contractor on the site. Directions given to the superintendent by the Owner's Authorized Representative shall be confirmed in writing to the Contractor.

## **B.7 INSPECTION**

B.7.1 Owner's Authorized Representative shall have access to the Work at all times.

B.7.2 Inspection of the Work will be made by the Owner's Authorized Representative at its discretion. The Owner's Authorized Representative will have authority to reject Work that does not conform to the Contract Documents. Any Work found to be not in conformance with the Contract Documents, in the discretion of the Owner's Authorized Representative, shall be removed and replaced at the Contractor's expense.

### **EXHIBIT 1, ATTACHMENT C – GENERAL CONDITIONS**



B.7.3 Contractor shall make or obtain at the appropriate time all tests, inspections and approvals of portions of the Work required by the Contract Documents or by laws, ordinances, rules, regulations or orders of public authorities having jurisdiction. Unless otherwise provided, the Contractor shall make arrangements for such tests, inspections and approvals with an independent testing laboratory or entity acceptable to the Owner, or with the appropriate public authority, and shall bear all related costs of tests, inspections and approvals. Tests or inspections conducted pursuant to the Contract Documents shall be made promptly to avoid unreasonable delay in the Work. The Contractor shall give the Owner's Authorized Representative timely notice of when and where tests and inspections are to be made so that the Owner's Authorized Representative may be present for such procedures. Required certificates of testing, inspection or approval shall, unless otherwise required by the Contract Documents, be secured by the Contractor and promptly delivered to the Owner's Authorized Representative.

B.7.4 As required by the Contract Documents, Work done or material used without inspection or testing by the Owner's Authorized Representative may be ordered removed at the Contractor's expense.

B.7.5 If directed to do so any time before the Work is accepted, the Contractor shall uncover portions of the completed Work for inspection. After inspection, the Contractor shall restore such portions of Work to the standard required by the Contract. If the Work uncovered is unacceptable or was done without sufficient notice to the Owner's Authorized Representative, the uncovering and restoration shall be done at the Contractor's expense. If the Work uncovered is acceptable and was done with sufficient notice to the Owner's Authorized Representative, the uncovering and restoration will be paid for as a Change Order.

B.7.6 If any testing or inspection reveals failure of the portions of the Work to comply with requirements established by the Contract Documents, all costs made necessary by such failure, including those of repeated procedures and compensation for the Owner's Authorized Representative's and Architect/Engineer's services and expenses, shall be at the Contractor's expense.

B.7.7 When the United States government participates in the cost of the Work, or the Owner has an agreement with other public or private organizations, or if any portion of the Work is being performed for a third party or in close proximity to third party facilities, representatives of these organizations have the right to inspect the Work affecting their interests or property. Their right to inspect shall not make them a party to the Contract and shall not interfere with the rights of the parties of the Contract. Instructions or orders of such parties shall be transmitted to the Contractor, through the Owner's Authorized Representative.

## **B.8 SEVERABILITY**

If any provision of this Contract is declared by a court to be illegal or in conflict with any law, the validity of the remaining terms and provisions shall not be affected and the rights and obligations of the parties shall be construed and enforced as if the Contract did not contain the particular provision held to be invalid.

## **B.9 ACCESS TO RECORDS**

B.9.1 Contractor shall keep, at all times on the Work site, one record copy of the complete Contract Documents, including the Plans, Specifications, Change Orders and addenda, in good order and marked currently to record field changes and selections made during construction, and one record copy of Shop Drawings, Product Data, Samples and similar submittals, and shall at all times give the Owner's Authorized Representative access thereto.

B.9.2 Contractor shall retain and the Owner and its duly authorized representatives shall have access to, for a period not less than six (6) years, all Record Documents, financial and accounting records, and other books, documents, papers and records of Contractor which are pertinent to the Contract including records pertaining to Overhead and indirect costs, for the purpose of making audit, examination, excerpts and transcripts. If for any reason, any part of the Contract is involved in litigation, Contractor shall retain all such records until all litigation is resolved. The Owner and/or its agents shall continue to be provided full access to the records during litigation.

## **B.10 WAIVER**

### **EXHIBIT 1, ATTACHMENT C – GENERAL CONDITIONS**

Failure of the Owner to enforce any provision of this Contract shall not constitute a waiver or relinquishment by the Owner of the right to such performance in the future nor of the right to enforce any other provision of this Contract.

#### **B.11 SUBCONTRACTS AND ASSIGNMENT**

B.11.1 Contractor shall require each Subcontractor, to the extent of the Work to be performed by the Subcontractor, to be bound by the terms and conditions of these General Conditions, and to assume toward the Contractor all of the obligations and responsibilities which the Contractor assumes toward the Owner thereunder, unless (1) the same are clearly inapplicable to the subcontract at issue because of legal requirements or industry practices, or (2) specific exceptions are requested by Contractor and approved in writing by Owner. Where appropriate, Contractor shall require each Subcontractor to enter into similar agreements with sub-subcontractors at any level.

B.11.2 At Owner's request, Contractor shall submit to Owner prior to their execution either Contractor's form of subcontract, or the subcontract to be executed with any particular Subcontractor. If Owner disapproves such form, Contractor shall not execute the form until the matters disapproved are resolved to Owner's satisfaction. Owner's review, comment upon or approval of any such form shall not relieve Contractor of its obligations under this Agreement or be deemed a waiver of such obligations of Contractor.

B.11.3 Contractor shall not assign, sell, or transfer its rights, or delegate its responsibilities under this Contract, in whole or in part, without the prior written approval of the Owner. No such written approval shall relieve Contractor of any obligations of this Contract, and any transferee shall be considered the agent of the Contractor and bound to perform in accordance with the Contract Documents. Contractor shall remain liable as between the original parties to the Contract as if no assignment had occurred.

#### **B.12 SUCCESSORS IN INTEREST**

The provisions of this Contract shall be binding upon and shall accrue to the benefit of the parties to the Contract and their respective permitted successors and assigns.

#### **B.13 OWNER'S RIGHT TO DO WORK**

Owner reserves the right to perform other or additional work at or near the project site with other forces than those of the Contractor. If such work takes place within or next to the project site, Contractor will coordinate work with the other contractors or forces, cooperate with all other contractors or forces, carry out the Work in a way that will minimize interference and delay for all forces involved, place and dispose of materials being used so as not to interfere with the operations of another, and join the Work with the work of the others in an acceptable manner and perform it in proper sequence to that of the others. The Owner's Authorized Representative will resolve any disagreements that may arise between or among Contractor and the other contractors over the method or order of doing all work (including the Work). In case of unavoidable interference, the Owner's Authorized Representative will establish work priority (including the Work) which generally will be in the sequence that the contracts were awarded.

#### **B.14 OTHER CONTRACTS**

In all cases and at any time, the Owner has the right to execute other contracts related to or unrelated to the Work of this Contract. The Contractor of this Contract will fully cooperate with any and all other contractors without additional cost to the Owner in the manner described in section B.13.

#### **B.15 GOVERNING LAW**

This Contract shall be governed by and construed in accordance with the laws of the State of Oregon without regard to principles of conflict of laws.

#### **B.16 LITIGATION**

### **EXHIBIT 1, ATTACHMENT C – GENERAL CONDITIONS**

Any Claim between Owner and Contractor that arises from or relates to this Contract and that is not resolved through the Claims Review Process in Section D.3 shall be brought and conducted solely and exclusively within the Circuit Court of Marion County for the State of Oregon; provided, however, if a Claim must be brought in a federal forum, then it shall be brought and conducted solely and exclusively within the United States District Court for the District of Oregon. In no event shall this section be construed as a waiver by the State of Oregon on any form of defense or immunity, whether sovereign immunity, governmental immunity, immunity based on the Eleventh Amendment to the Constitution of the United States or otherwise, from any claim or from the jurisdiction of any court. CONTRACTOR BY EXECUTION OF THIS CONTRACT HEREBY CONSENTS TO THE IN PERSONAM JURISDICTION OF THE COURTS REFERENCED IN THIS SECTION B.16.

### **B.17 ALLOWANCES**

B.17.1 The Contractor shall include in the Contract Price all allowances stated in the Contract Documents. Items covered by allowances shall be supplied for such amounts and by such persons or entities as the Owner may direct.

B.17.2 Unless otherwise provided in the Contract Documents:

- (a) when finally reconciled, allowances shall cover the cost to the Contractor of materials and equipment delivered at the site and all required taxes, less applicable trade discounts;
- (b) Contractor's costs for unloading and handling at the site, labor, installation costs, Overhead, profit and other expenses contemplated for stated allowance amounts shall be included in the Contract Price but not in the allowances;
- (c) whenever costs are more than or less than allowances, the Contract Price shall be adjusted accordingly by Change Order. The amount of the Change Order shall reflect (i) the difference between actual costs and the allowances under Section B.17.2(a) and (2) changes in Contractor's costs under Section B.17.2(b).
- (d) Unless Owner requests otherwise, Contractor shall provide to Owner a proposed fixed price for any allowance work prior to its performance.

### **B.18 SUBMITTALS, SHOP DRAWINGS, PRODUCT DATA AND SAMPLES**

B.18.1 The Contractor shall prepare and keep current, for the Architect's/Engineer's approval (or for the approval of Owner's Authorized Representative if approval authority has not been delegated to the Architect/Engineer), a schedule and list of submittals which is coordinated with the Contractor's construction schedule and allows the Architect/Engineer reasonable time to review submittals. Owner reserves the right to finally approve the schedule and list of submittals. Submittals include, without limitation, Shop Drawings, Product Data, and Samples which are described below:

- (a) Shop Drawings are drawings, diagrams, schedules and other data specially prepared for the Work by the Contractor or a Subcontractor (including any sub-subcontractor), manufacturer, supplier or distributor to illustrate some portion of the Work.
- (b) Product Data are illustrations, standard schedules, performance charts, instructions, brochures, diagrams and other information furnished by the Contractor to illustrate materials or equipment for some portion of the Work.
- (c) Samples are physical examples which illustrate materials, equipment or workmanship and establish standards by which the Work will be judged.

B.18.2 Shop Drawings, Product Data, Samples and similar submittals are not Contract Documents. The purpose of their submittal is to demonstrate for those portions of the Work for which submittals are required by the Contract Documents the way by which the Contractor proposes to conform to the information given and the design concept expressed in the Contract Documents. Review of submittals by the Architect/Engineer is not conducted for the

### **EXHIBIT 1, ATTACHMENT C – GENERAL CONDITIONS**

purpose of determining the accuracy and completeness of other details such as dimensions and quantities, or for substantiating instructions for installation or performance of equipment or systems, or for approval of safety precautions or, unless otherwise specifically stated by the Architect/Engineer, of any construction means, methods, techniques, sequences or procedures, all of which remain the responsibility of the Contractor as required by the Contract Documents. The Architect/Engineer's review of the Contractor's submittals shall not relieve the Contractor of its obligations under the Contract Documents. The Architect/Engineer's approval of a specific item shall not indicate approval of an assembly of which the item is a component. Informational submittals upon which the Architect/Engineer is not expected to take responsive action may be so identified in the Contract Documents. Submittals which are not required by the Contract Documents may be returned by the Architect/Engineer without action.

B.18.3 The Contractor shall review for compliance with the Contract Documents, approve and submit to the Architect/Engineer Shop Drawings, Product Data, Samples and similar submittals required by the Contract Documents with reasonable promptness and in such sequence as to cause no delay in the Work or in the activities of the Owner or of separate contractors. Submittals which are not marked as reviewed for compliance with the Contract Documents and approved by the Contractor may be returned by the Architect/Engineer without action.

B.18.4 By approving and submitting Shop Drawings, Product Data, Samples and similar submittals, the Contractor represents that the Contractor has determined and verified materials, field measurements and field construction criteria related thereto, or will do so, and has checked and coordinated the information contained within such submittals with the requirements of the Work and of the Contract Documents.

B.18.5 The Contractor shall perform no portion of the Work for which the Contract Documents require submittal and review of Shop Drawings, Product Data, Samples or similar submittals until the respective submittal has been approved by the Architect/Engineer.

B.18.6 The Work shall be in accordance with approved submittals except that the Contractor shall not be relieved of responsibility for deviations from requirements of the Contract Documents by the Architect/Engineer's review or approval of Shop Drawings, Product Data, Samples or similar submittals unless the Contractor has specifically informed the Architect/Engineer in writing of such deviation at the time of submittal and (i) the Architect/Engineer has given written approval to the specific deviation as a minor change in the Work, or (ii) a Change Order has been executed by Owner authorizing the deviation. The Contractor shall not be relieved of responsibility for errors or omissions in Shop Drawings, Product Data, Samples or similar submittals by the Architect/Engineer's review or approval thereof.

B.18.7 In the event that Owner elects not to have the obligations and duties described under this Section B.18 performed by the Architect/Engineer, or in the event no Architect/Engineer is employed by Owner on the project, all obligations and duties assigned to the Architect/Engineer hereunder shall be performed by the Owner's Authorized Representative.

## **B.19 SUBSTITUTIONS**

The Contractor may make Substitutions only with the consent of the Owner, after evaluation by the Owner's Authorized Representative and only in accordance with a Change Order. Substitutions shall be subject to the requirements of the bid documents. By making requests for Substitutions, the Contractor represents that the Contractor has personally investigated the proposed substitute product; represents that the Contractor will provide the same warranty for the Substitution that the Contractor would for the product originally specified unless approved otherwise; certifies that the cost data presented is complete and includes all related costs under this Contract including redesign costs, and waives all claims for additional costs related to the Substitution which subsequently become apparent; and will coordinate the installation of the accepted Substitution, making such changes as may be required for the Work to be completed in all respects.

## **B.20 USE OF PLANS AND SPECIFICATIONS**

### **EXHIBIT 1, ATTACHMENT C – GENERAL CONDITIONS**

Plans, Specifications and related Contract Documents furnished to Contractor by Owner or Owner's Architect/Engineer shall be used solely for the performance of the Work under this Contract. Contractor and its Subcontractors and suppliers are authorized to use and reproduce applicable portions of such documents appropriate to the execution of the Work, but shall not claim any ownership or other interest in them beyond the scope of this Contract, and no such interest shall attach. Unless otherwise indicated, all common law, statutory and other reserved rights, in addition to copyrights, are retained by Owner.

#### **B.21 FUNDS AVAILABLE AND AUTHORIZED**

Owner reasonably believes at the time of entering into this Contract that sufficient funds are available and authorized for expenditure to finance the cost of this Contract within the Owner's appropriation or limitation. Contractor understands and agrees that, to the extent that sufficient funds are not available and authorized for expenditure to finance the cost of this Contract, Owner's payment of amounts under this Contract attributable to Services performed after the last day of the current biennium is contingent on Owner receiving from the Oregon Legislative Assembly appropriations, limitations or other expenditure authority sufficient to allow Owner, in the exercise of its reasonable administrative discretion, to continue to make payments under this Contract.

#### **B.22 NO THIRD PARTY BENEFICIARIES**

Owner and Contractor are the only parties to this Contract and are the only parties entitled to enforce its terms. Nothing in this Contract gives, is intended to give, or shall be construed to give or provide any benefit or right, whether directly, indirectly, or otherwise, to third persons unless such third persons are individually identified by name herein and expressly described as intended beneficiaries of the terms of this Contract.

### **SECTION C *WAGES AND LABOR***

#### **C.1 MINIMUM WAGE RATES ON PUBLIC WORKS**

Contractor shall comply fully with the provisions of ORS 279C.800 through 279C.870. Documents establishing those conditions, as determined by the Commissioner of the Bureau of Labor and Industries (BOLI), are included as attachments to or are incorporated by reference in the Contract Documents. Contractor shall pay workers at not less than the specified minimum hourly rate of wage, and shall include that requirement in all subcontracts.

#### **C.2 PAYROLL CERTIFICATION; ADDITIONAL RETAINAGE; FEE REQUIREMENTS**

C.2.1 In accordance with ORS 279C.845, the Contractor and every Subcontractor shall submit written certified statements to the Owner's Authorized Representative, on the form prescribed by the Commissioner of the Bureau of Labor and Industries, certifying the hourly rate of wage paid each worker which the Contractor or the Subcontractor has employed on the project and further certifying that no worker employed on the project has been paid less than the prevailing rate of wage or less than the minimum hourly rate of wage specified in the Contract, which certificate and statement shall be verified by the oath of the Contractor or the Subcontractor that the Contractor or Subcontractor has read the certified statement, that the Contractor or Subcontractor knows the contents of the certified statement and that to the Contractor's or Subcontractor's best knowledge and belief the certified statement is true. The certified statements shall set out accurately and completely the payroll records for the prior week including the name and address of each worker, the worker's correct classification, rate of pay, daily and weekly number of hours worked, deductions made and actual wages paid. Certified statements for each week during which the Contractor or Subcontractor has employed a worker on the project shall be submitted once a month, by the fifth business day of the following month.

The Contractor and Subcontractors shall preserve the certified statements for a period of six (6) years from the date of completion of the Contract.

### **EXHIBIT 1, ATTACHMENT C – GENERAL CONDITIONS**

C.2.2 Pursuant to ORS 279C.845(7), the Owner shall retain 25 percent of any amount earned by the Contractor on this public works project until the Contractor has filed the certified statements required by section C.2.1. The Owner shall pay to the Contractor the amount retained under this subsection within 14 days after the Contractor files the required certified statements, regardless of whether a Subcontractor has failed to file certified statements.

C.2.3 Pursuant to ORS 279C.845(8), the Contractor shall retain 25 percent of any amount earned by a first-tier Subcontractor on this public works project until the first-tier Subcontractor has filed with the Owner the certified statements required by C.2.1. Before paying any amount retained under this subsection, the Contractor shall verify that the first-tier Subcontractor has filed the certified statement. Within 14 days after the first-tier Subcontractor files the required certified statement the Contractor shall pay the first-tier Subcontractor any amount retained under this subsection.

C.2.4 In accordance with statutory requirements, and administrative rules promulgated by the Commissioner of the Bureau of Labor and Industries, the fee required by ORS 279C.825(1) will be paid by Owner to the Commissioner.

### **C.3 PROMPT PAYMENT AND CONTRACT CONDITIONS**

C.3.1 Pursuant to ORS 279C.505 and as a condition to Owner's performance hereunder, the Contractor shall:

C.3.1.1 Make payment promptly, as due, to all persons supplying to Contractor labor or materials for the prosecution of the Work provided for in this Contract.

C.3.1.2 Pay all contributions or amounts due the State Industrial Accident Fund from such Contractor or Subcontractor incurred in the performance of the Contract.

C.3.1.3 Not permit any lien or claim to be filed or prosecuted against the Owner on account of any labor or material furnished. Contractor will not assign any claims that Contractor has against Owner, or assign any sums due by Owner, to Subcontractors, suppliers, or manufacturers, and will not make any agreement or act in any way to give Subcontractors a claim or standing to make a claim against the Owner.

C.3.1.4 Pay to the Department of Revenue all sums withheld from employees pursuant to ORS 316.167.

C.3.1.5 Demonstrate that an employee drug testing program is in place as follows:

(a) Contractor represents and warrants that Contractor has in place at the time of the execution of this Contract, and shall maintain during the term of this Contract, a Qualifying Employee Drug Testing Program for its employees that includes, at a minimum, the following:

(1) A written employee drug testing policy,

(2) Required drug testing for all new Subject Employees or, alternatively, required testing of all Subject Employees every 12 months on a random selection basis, and

(3) Required testing of a Subject Employee when the Contractor has reasonable cause to believe the Subject Employee is under the influence of drugs.

A drug testing program that meets the above requirements will be deemed a "Qualifying Employee Drug Testing Program." For the purposes of this section, an employee is a "Subject Employee" only if that employee will be working on the project job site.

(b) Contractor shall require each Subcontractor providing labor for the project to:

### **EXHIBIT 1, ATTACHMENT C – GENERAL CONDITIONS**

(1) Demonstrate to the Contractor that it has a Qualifying Employee Drug Testing Program for the Subcontractor's Subject Employees, and represent and warrant to the Contractor that the Qualifying Employee Drug Testing Program is in place at the time of subcontract execution and will continue in full force and effect for the duration of the subcontract, or

(2) Require that the Subcontractor's Subject Employees participate in the Contractor's Qualifying Employee Drug Testing Program for the duration of the subcontract.

C.3.2 Pursuant to ORS 279C.515, and as a condition to Owner's performance hereunder, Contractor agrees:

C.3.2.1 If Contractor fails, neglects or refuses to make prompt payment of any claim for labor or services furnished to the Contractor or a Subcontractor by any person in connection with the project as such claim becomes due, the proper officer(s) representing the Owner may pay the claim and charge the amount of the payment against funds due or to become due Contractor under this Contract. Payment of claims in this manner shall not relieve the Contractor or the Contractor's surety from obligation with respect to any unpaid claims.

C.3.2.2 If the Contractor or a first-tier Subcontractor fails, neglects or refuses to make payment to a person furnishing labor or materials in connection with the public contract for a public improvement within thirty (30) Days after receipt of payment from Owner or a contractor, the contractor or first-tier Subcontractor shall owe the person the amount due plus interest charges commencing at the end of the 10-Day period that payment is due under ORS 279C.580(3) and ending upon final payment, unless payment is subject to a good faith dispute as defined in ORS 279C.580. The rate of interest charged to the Contractor or first-tier Subcontractor on the amount due shall equal three times the discount rate on 90-Day commercial paper in effect at the Federal Reserve Bank in the Federal Reserve district that includes Oregon on the date that is thirty (30) Days after the date when payment was received from Owner or from the Contractor, but the rate of interest shall not exceed thirty (30) percent. The amount of interest may not be waived.

C.3.2.3 If the Contractor or a Subcontractor fails, neglects or refuses to make payment to a person furnishing labor or materials in connection with the Contract, the person may file a complaint with the Construction Contractors Board, unless payment is subject to a good faith dispute as defined in ORS 279C.580. Every contract related to this Contract shall contain a similar clause.

C.3.3 Pursuant to ORS 279C.580, Contractor shall include in each subcontract for property or services entered into by the Contractor and a first-tier Subcontractor, including a material supplier, for the purpose of performing a construction contract:

- (a) A payment clause that obligates the Contractor to pay the first-tier Subcontractor for satisfactory performance under its subcontract within ten (10) Days out of such amounts as are paid to the Contractor by Owner under the Contract;
- (b) An interest penalty clause that obligates the Contractor if payment is not made within thirty (30) Days after receipt of payment from Owner, to pay to the first-tier Subcontractor an interest penalty on amounts due in the case of each payment not made in accordance with the payment clause included in the subcontract pursuant to paragraph (a) of this subsection. Contractor or first-tier Subcontractor shall not be obligated to pay an interest penalty if the only reason that the Contractor or first-tier Subcontractor did not make payment when payment was due is that the Contractor or first-tier Subcontractor did not receive payment from Owner or Contractor when payment was due. The interest penalty shall be for the period beginning on the day after the required payment date and ending on the date on which payment of the amount due is made; and shall be computed at the rate specified in ORS 279C.515(2).

(c) A clause which requires each of Contractor's Subcontractor's to include, in each of their contracts with lower-tier Subcontractors or suppliers, provisions to the effect that the first-tier Subcontractor shall pay its lower-tier Subcontractors and suppliers in accordance with the provisions of subsections (a) and (b), above and requiring each of their Subcontractors and suppliers to include such clauses in their subcontracts and supply contracts.

#### **EXHIBIT 1, ATTACHMENT C – GENERAL CONDITIONS**

C.3.4 All employers, including Contractor, that employ subject workers who work under this contract in the State of Oregon shall comply with ORS 656.017 and provide the required Workers' Compensation coverage, unless such employers are exempt under ORS 656.126. Contractor shall ensure that each of its Subcontractors complies with these requirements.

#### **C.4 PAYMENT FOR MEDICAL CARE**

Pursuant to ORS 279C.530, and as a condition to Owner's performance hereunder, Contractor shall promptly, as due, make payment to any person, partnership, association or corporation furnishing medical, surgical, and hospital care or other needed care and attention, incident to sickness or injury, to the employees of such Contractor, all sums of which the Contractor agrees to pay for such services and all moneys and sums which the Contractor has collected or deducted from the wages of personnel pursuant to any law, contract or agreement for the purpose of providing or paying for such services.

#### **C.5 HOURS OF LABOR**

As a condition to Owner's performance hereunder, Contractor shall comply with ORS 279C.520, as amended from time to time and incorporated herein by this reference:

Pursuant to ORS 279C.520 and as a condition to Owner's performance hereunder, no person shall be employed to perform Work under this Contract for more than ten (10) hours in any one day or forty (40) hours in any one week, except in cases of necessity, emergency or where public policy absolutely requires it. In such instances, Contractor shall pay the employee at least time and a half pay:

- (a) For all overtime in excess of eight (8) hours a day or forty (40) hours in any one week when the work week is five consecutive Days, Monday through Friday; or
- (b) For all overtime in excess of ten (10) hours a day or forty (40) hours in any one week when the work week is four consecutive Days, Monday through Friday; and
- (c) For all Work performed on Saturday and on any legal holiday specified in ORS 279C.540.

This section C.5 will not apply to Contractor's Work under this Contract if Contractor is currently a party to a collective bargaining agreement with any labor organization.

This Section C.5 shall not excuse Contractor from completion of the Work within the time required under this Contract.

### **SECTION D** *CHANGES IN THE WORK*

#### **D.1 CHANGES IN WORK**

D.1.1 The terms of this Contract shall not be waived, altered, modified, supplemented or amended in any manner whatsoever without prior written approval of the Owner's Authorized Representative, and then only in a manner consistent with the Change Order provisions of this Section D.1 and after any necessary approvals required by public contracting laws have been obtained. Otherwise, a formal contract amendment is required, which shall not be effective until its execution by the parties to this Contract and all approvals required by public contracting laws have been obtained.

D.1.2 It is mutually agreed that changes in Plans, quantities, or details of construction are inherent in the nature of construction and may be necessary or desirable during the course of construction. Within the general scope of this Contract, the Owner's Authorized Representative may at any time, without notice to the sureties and without

#### **EXHIBIT 1, ATTACHMENT C – GENERAL CONDITIONS**



impairing the Contract, require changes consistent with this Section D.1. All Change Order Work shall be executed under the conditions of the Contract Documents. Such changes may include, but are not limited to:

- (a) Modification of specifications and design.
- (b) Increases or decreases in quantities.
- (c) Increases or decreases to the amount of Work.
- (d) Addition or elimination of any Work item.
- (e) Change in the duration of the project.
- (f) Acceleration or delay in performance of Work.
- (g) Deductive changes.

Deductive changes are those that reduce the scope of the Work, and shall be made by mutual agreement whenever feasible. In cases of suspension or partial termination under Section J, Owner reserves the right to unilaterally impose a deductive change and to self perform such Work, for which the provisions of B.13 (Owner's Right to Do Work) shall then apply.

Adjustments in compensation shall be made under the provisions of D.1.3, in which costs for deductive changes shall be based upon a Direct Costs adjustment together with the related percentage markup specified for profit, Overhead and other indirect costs, unless otherwise agreed to by Owner.

D.1.3 The Owner and Contractor agree that Change Order Work shall be administered and compensated according to the following:

- (a) *Unit pricing* may be utilized at the Owner's option when unit prices or solicitation alternates were provided that established the cost for additional Work, and a binding obligation exists under the Contract on the parties covering the terms and conditions of the additional Work.
- (b) If the Owner elects not to utilize unit pricing, or in the event that unit pricing is not available or appropriate, *fixed pricing* may be used for Change Order Work. In fixed pricing the basis of payments or total price shall be agreed upon in writing between the parties to the Contract, and shall be established before the Work is done whenever feasible. The mark-ups set forth in D.1.3(c) shall be utilized by the parties as a guide in establishing fixed pricing, and will not be exceeded by Owner without adequate justification. Cost and price data relating to Change Orders shall be supplied by Contractor to Owner upon request, but Owner shall be under no obligation to make such requests.
- (c) In the event that unit pricing and fixed pricing are not utilized, then Change Order Work shall be performed on a *cost reimbursement* basis for Direct Costs. Such Work shall be compensated on the basis of the actual, reasonable and allowable cost of labor, equipment, and material furnished on the Work performed. In addition, the following markups shall be added to the Contractor's or Subcontractor's Direct Costs as full compensation for profit, Overhead and other indirect costs for Work directly performed with the Contractor's or Subcontractor's own forces:

On Labor.....	10%
On Equipment.....	10%
On Materials.....	10%

When Change Order Work under D.1.3(c) is invoiced by an authorized Subcontractor at any level, each ascending tier Subcontractor or Contractor will be allowed a supplemental mark-up on each piece of subcontract Work covered by such Change Order as follows:

**EXHIBIT 1, ATTACHMENT C – GENERAL CONDITIONS**

\$0.00 - \$5,000.00 10%, and then  
Over \$5,000.00 5%

Payments made to the Contractor shall be complete compensation for Overhead, profit, and all costs that were incurred by the Contractor or by other forces furnished by the Contractor, including Subcontractors, for Change Order Work. Owner may establish a maximum cost for Change Order Work under this Section D.1.3(c), which shall not be exceeded for reimbursement without additional written authorization from Owner. Contractor shall not be required to complete such Change Order Work without additional authorization.

D.1.4 Any necessary adjustment of Contract Time that may be required as a result of a Change Order must be agreed upon by the parties before the start of the Change Order Work unless Owner's Authorized Representative authorizes Contractor to start the Work before agreement on Contract Time adjustment. Contractor shall submit any request for additional compensation (and additional Contract Time if Contractor was authorized to start Work before an adjustment of Contract Time was approved) as soon as possible but no later than thirty (30) Days after receipt of the Change Order. If Contractor's request for additional compensation or adjustment of Contract Time is not made within the thirty (30) day time limit, Contractor's requests pertaining to that Change Order are barred. The thirty (30) day time limit for making requests shall not be extended for any reason, including without limitation Contractor's claimed inability to determine the amount of additional compensation or adjustment of Contract Time, unless an extension is granted in writing by Owner. If the Owner's Authorized Representative denies Contractor's request for additional compensation or adjustment of Contract Time, Contractor may proceed to file a Claim under Section D.3, Claims Review Process. No other reimbursement, compensation, or payment will be made, except as provided in Section D.1.5 for impact claims.

D.1.5 If any Change Order Work under Section D.1.3 causes an increase or decrease in the Contractor's cost of, or the Contract Time required for the performance of, any other part of the Work under this Contract, the Contractor must submit a written request to the Owner's Authorized Representative, setting forth the nature and specific extent of the request, including all time and cost impacts against the Contract as soon as possible, but no later than thirty (30) Days after receipt of the Change Order by Contractor.

The thirty (30) day time limit applies to claims of Subcontractors, suppliers, or manufacturers that may be affected by the Change Order and that request additional compensation or an extension of Contract Time to perform; Contractor has responsibility for contacting its Subcontractors, suppliers, or manufacturers within the thirty (30) day time limit, and including their requests with Contractor's requests. If the request involves Work to be completed by Subcontractors, or materials to be furnished by suppliers or manufacturers, such requests shall be submitted to the Contractor in writing with full analysis and justification for the compensation and additional Contract Time requested. The Contractor will analyze and evaluate the merits of the requests submitted by Subcontractors, suppliers, and manufacturers to Contractor prior to including those requests and Contractor's analysis and evaluation of those requests with Contractor's requests for additional compensation or Contract Time that Contractor submits to the Owner's Authorized Representative. Failure of Subcontractors, suppliers, manufacturers or others to submit their requests to Contractor for inclusion with Contractor's requests submitted to Owner's Authorized Representative within the time period and by the means described in this section shall constitute a waiver of these Subcontractor claims. The Owner's Authorized Representative and the Owner will not consider direct requests or claims from Subcontractors, suppliers, manufacturers or others not a party to this Contract. The consideration of such requests and claims under this section does not give any person, not a party to the Contract the right to bring a claim against the State of Oregon, whether in this claims process, in litigation, or in any dispute resolution process.

If the Owner's Authorized Representative denies the Contractor's request for additional compensation or an extension of Contract Time, the Contractor may proceed to file a Claim under Section D.3, Claims Review Process.

D.1.6 No request or Claim by the Contractor for additional costs or an extension of Contract Time shall be allowed if made after receipt of final payment application under this Contract. Contractor agrees to submit its final payment application within ninety (90) days after Substantial Completion, unless written extension is granted by Owner. Contractor shall not delay final payment application for any reason, including without limitation nonpayment of Subcontractors, suppliers, manufacturers or others not a party to this Contract, or lack of resolution of a dispute with Owner or any other person of matters arising out of or relating to the Contract. If Contractor fails

#### **EXHIBIT 1, ATTACHMENT C – GENERAL CONDITIONS**

to submit its final payment application within ninety (90) days after Substantial Completion, and Contractor has not obtained written extension by Owner, all requests or Claims for additional costs or an extension of Contract Time shall be waived.

D.1.7 It is understood that changes in the Work are inherent in construction of this type. The number of changes, the scope of those changes, and the effect they have on the progress of the original Work cannot be defined at this time. The Contractor is notified that numerous changes may be required and that there will be no compensation made to the Contractor directly related to the number of changes. Each change will be evaluated for extension of Contract Time and increase or decrease in compensation based on its own merit.

## **D.2 DELAYS**

D.2.1 Delays in construction include “Avoidable Delays”, which are defined in Section D.2.1.1, and “Unavoidable Delays”, which are defined in Section D.2.1.2. The effect of Avoidable Delays is described in Section D.2.2 and the effect of Unavoidable Delays is described in Section D.2.3.

D.2.1.1 Avoidable Delays include any delays other than Unavoidable Delays, and include delays that otherwise would be considered Unavoidable Delays but that:

- (a) Could have been avoided by the exercise of care, prudence, foresight, and diligence on the part of the Contractor or its Subcontractors.
- (b) Affect only a portion of the Work and do not necessarily prevent or delay the prosecution of other parts of the Work nor the completion of the whole Work within the Contract Time.
- (c) Do not impact activities on the accepted critical path schedule.
- (d) Are associated with the reasonable interference of other contractors employed by the Owner that do not necessarily prevent the completion of the whole Work within the Contract Time.

D.2.1.2 Unavoidable Delays include delays other than Avoidable Delays that are:

- (a) Caused by any actions of the Owner, Owner’s Authorized Representative, or any other employee or agent of the Owner, or by separate contractor employed by the Owner.
- (b) Caused by any site conditions which differ materially from what was represented in the Contract Documents or from conditions that would normally be expected to exist and be inherent to the construction activities defined in the Contract Documents. The Contractor shall notify the Owner’s Authorized Representative immediately of differing site conditions before the area has been disturbed. The Owner’s Authorized Representative will investigate the area and make a determination as to whether or not the conditions differ materially from either the conditions stated in the Contract Documents or those which could reasonably be expected in execution of this particular Contract. If Contractor and the Owner’s Authorized Representative agree that a differing site condition exists, any additional compensation or additional Contract Time will be determined based on the process set forth in Section D.1.5 for Change Order Work. If the Owner’s Authorized Representative disagrees that a differing site condition exists and denies Contractor’s request for additional compensation or Contract Time, Contractor may proceed to file a Claim under Section D.3, Claims Review Process.
- (c) Caused by Force Majeure acts, events or occurrences that could not have been avoided by the exercise of care, prudence, foresight, and diligence on the part of the Contractor or its Subcontractors.
- (d) Caused by adverse weather conditions. Any adverse weather conditions must be substantiated by documentary evidence that weather conditions were abnormal for the specific time period claimed, could not have been anticipated by the Contractor, and adversely impacted the project in a manner that could not be avoided by rescheduling the Work or by implementing measures to protect against the weather so that the Work could proceed. A rain, windstorm, high water, or other natural phenomenon for the specific locality of the Work, which might

### **EXHIBIT 1, ATTACHMENT C – GENERAL CONDITIONS**

reasonably have been anticipated from the previous 10-year historical records of the general locality of the Work, shall not be construed as abnormal. The parties agree that rainfall greater than the following levels cannot be reasonably anticipated:

(i) Daily rainfall equal to, or greater than, 0.50 inch during a month when the monthly rainfall exceeds the normal monthly average by twenty-five percent (25 %) or more.

(ii) daily rainfall equal to, or greater than, 0.75 inch at any time.

The Office of the Environmental Data Service of the National Oceanic and Atmospheric Administration of the U.S. Department of Commerce nearest the project site shall be considered the official agency of record for weather information.

D.2.2 Except as otherwise provided in ORS 279C.315, Contractor shall not be entitled to additional compensation or additional Contract Time for Avoidable Delays.

D.2.3 In the event of Unavoidable Delays, based on principles of equitable adjustment, Contractor may be entitled to the following:

(a) Contractor may be entitled to additional compensation or additional Contract Time, or both, for Unavoidable Delays described in Section D.2.1.2 (a) and (b).

(b) Contractor may be entitled to additional Contract Time for Unavoidable Delays described in Section D.2.1.2(c) and (d).

In the event of any requests for additional compensation or additional Contract Time, or both, as applicable, arising under this Section D.2.3 for Unavoidable Delays, other than requests for additional compensation or additional Contract Time for differing site conditions for which a review process is established under Section D.2.1.2 (b), Contractor shall submit a written notification of the delay to the Owner's Authorized Representative within two (2) Days of the occurrence of the cause of the delay. This written notification shall state the cause of the potential delay, the project components impacted by the delay, and the anticipated additional Contract Time or the additional compensation, or both, as applicable, resulting from the delay. Within seven (7) Days after the cause of the delay has been mitigated, or in no case more than thirty (30) Days after the initial written notification, the Contractor shall submit to the Owner's Authorized Representative, a complete and detailed request for additional compensation or additional Contract Time, or both, as applicable, resulting from the delay. If the Owner's Authorized Representative denies Contractor's request for additional compensation or adjustment of Contract Time, the Contractor may proceed to file a Claim under Section D.3, Claims Review Process.

If Contractor does not timely submit the notices required under this Section D.2., then unless otherwise prohibited by law, Contractor's Claim shall be barred.

### **D.3 CLAIMS REVIEW PROCESS**

D.3.1 All Contractor Claims shall be referred to the Owner's Authorized Representative for review. Contractor's Claims, including Claims for additional compensation or additional Contract Time, shall be submitted in writing by Contractor to the Owner's Authorized Representative within five (5) Days after a denial of Contractor's initial request for an adjustment of Contract terms, payment of money, extension of Contract Time or other relief, provided that such initial request has been submitted in accordance with the requirements and within the time limits established in these General Conditions. Within thirty (30) Days after the initial Claim, Contractor shall submit to the Owner's Authorized Representative, a complete and detailed description of the Claim (the "Detailed Notice") that includes all information required by Section D.3.2. Unless the Claim is made in accordance with these time requirements, it shall be waived.

D.3.2 The Detailed Notice of the Claim shall be submitted in writing by Contractor and shall include a detailed, factual statement of the basis of the Claim, pertinent dates, Contract provisions which support or allow the Claim,

### **EXHIBIT 1, ATTACHMENT C – GENERAL CONDITIONS**

reference to or copies of any documents which support the Claim, the dollar value of the Claim, and the Contract Time extension requested for the Claim. If the Claim involves Work to be completed by Subcontractors, the Contractor will analyze and evaluate the merits of the Subcontractor claim prior to forwarding it and that analysis and evaluation to the Owner's Authorized Representative. The Owner's Authorized Representative and the Owner will not consider direct claims from Subcontractors, suppliers, manufacturers, or others not a party to this Contract. Contractor agrees that it will make no agreement, covenant, or assignment, nor will it commit any other act that will permit or assist any Subcontractor, supplier, manufacturer, or other to directly or indirectly make a claim against Owner.

D.3.3 The Owner's Authorized Representative will review all Claims and take one or more of the following preliminary actions within ten (10) Days of receipt of the Detailed Notice of a Claim: (1) request additional supporting information from the Contractor; (2) inform the Contractor and Owner in writing of the time required for adequate review and response; (3) reject the Claim in whole or in part and identify the reasons for rejection; (4) based on principles of equitable adjustment, recommend approval of all or part of the Claim; or (5) propose an alternate resolution.

D.3.4 The Owner's Authorized Representative's decision shall be final and binding on the Contractor unless appealed by written notice to the Owner within fifteen (15) Days of receipt of the decision. The Contractor must present written documentation supporting the Claim within fifteen (15) Days of the notice of appeal. After receiving the appeal documentation, the Owner shall review the materials and render a decision within thirty (30) Days after receiving the appeal documents.

D.3.5 The decision of the Owner shall be final and binding unless the Contractor delivers to the Owner its requests for mediation, which shall be a non-binding process, within fifteen (15) Days of the date of the Owner's decision. The mediation process will be considered to have commenced as of the date the Contractor delivers the request. Both parties acknowledge and agree that participation in mediation is a prerequisite to commencement of litigation of any disputes relating to the Contract. Both parties further agree to exercise their best efforts in good faith to resolve all disputes within sixty (60) Days of the commencement of the mediation through the mediation process set forth herein.

In the event that a lawsuit must be filed within this sixty (60) day period in order to preserve a cause of action, the parties agree that notwithstanding the filing, they shall proceed diligently with the mediation to its conclusion prior to actively prosecuting the lawsuit, and shall seek from the Court in which the lawsuit is pending such stays or extensions, including the filing of an answer, as may be necessary to facilitate the mediation process. Further, in the event settlements are reached on any issues through mediation, the parties agree to promptly submit the appropriate motions and orders documenting the settlement to the Court for its signature and filing.

D.3.6 The mediator shall be an individual mutually acceptable to both parties, but in the absence of agreement each party shall select a temporary mediator and the temporary mediators shall jointly select the permanent mediator. Each party shall pay its own costs for the time and effort involved in mediation. The cost of the mediator shall be split equally between the two parties. Both parties agree to exercise their best effort in good faith to resolve all disputes in mediation. Participation in mediation is a mandatory requirement of both the Owner and the Contractor. The schedule, time and place for mediation will be mutually acceptable, or, failing mutual agreement, shall be as established by the mediator. The parties agree to comply with Owner's administrative rules governing the confidentiality of mediation, if any, and shall execute all necessary documents to give effect to such confidentiality rules. In any event, the parties shall not subpoena the mediator or otherwise require the mediator to produce records, notes or work product, or to testify in any future proceedings as to information disclosed or representations made in the course of mediation, except to the extent disclosure is required by law.

D.3.7 Owner may at any time and at its discretion issue a construction change directive adding to, modifying or reducing the scope of Work. Contractor and Owner shall negotiate the need for any additional compensation or additional Contract Time related to the change, subject to the procedures for submitting requests or Claims for additional compensation or additional Contract Time established in this Section D. Unless otherwise directed by Owner's Authorized Representative, Contractor shall proceed with the Work while any request or Claim is pending, including but not limited to, a request or Claim for additional compensation or additional Contract Time resulting

#### **EXHIBIT 1, ATTACHMENT C – GENERAL CONDITIONS**

from Work under a Change Order or construction change directive. Regardless of the review period or the final decision of the Owner's Authorized Representative, the Contractor shall continue to diligently pursue the Work as identified in the Contract Documents. In no case is the Contractor justified or allowed to cease Work without a written stop work order from the Owner or Owner's Authorized Representative.

## **SECTION E PAYMENTS**

### **E.1 SCHEDULE OF VALUES**

The Contractor shall submit, at least ten (10) Days prior to submission of its first application for progress payment, a schedule of values ("Schedule of Values") for the contracted Work. This schedule will provide a breakdown of values for the contracted Work and will be the basis for progress payments. The breakdown will demonstrate reasonable, identifiable, and measurable components of the Work. Unless objected to by the Owner's Authorized Representative, this schedule shall be used as the basis for reviewing Contractor's applications for payment. If objected to by Owner's Authorized Representative, Contractor shall revise the schedule of values and resubmit the same for approval of Owner's Authorized Representative.

### **E.2 APPLICATIONS FOR PAYMENT**

E.2.1 Owner shall make progress payments on the Contract monthly as Work progresses. Payments shall be based upon estimates of Work completed and the Schedule of Values. All payments shall be approved by the Owner's Authorized Representative. A progress payment shall not be considered acceptance or approval of any Work or waiver of any defects therein. Owner shall pay to Contractor interest on the progress payment, not including retainage, due the Contractor. The interest shall commence thirty (30) Days after the receipt of invoice ("application for payment") from the Contractor or fifteen (15) Days after the payment is approved by the Owner's Authorized Representative, whichever is the earlier date. The rate of interest shall equal three times the discount rate on 90-day commercial paper in effect at the Federal Reserve Bank in the Federal Reserve district that includes Oregon on the date that is thirty (30) Days after receipt of the application for payment from the Contract or fifteen (15) Days after the payment is approved by the Owner, whichever is the earlier date, but the rate of interest shall not exceed thirty (30) percent. Notwithstanding the foregoing, in instances when an application for payment is filled out incorrectly, or when there is any defect or impropriety in any submitted application or when there is a good faith dispute, Owner shall so notify the Contractor within fifteen (15) Days stating the reason or reasons the application for payment is defective or improper or the reasons for the dispute. A defective or improper application for payment, if corrected by the Contractor within seven (7) Days of being notified by the Owner, shall not cause a payment to be made later than specified in this section unless interest is also paid. Accrual of interest will be postponed when payment on the principal is delayed because of disagreement between the Owner and the Contractor.

Owner reserves the right, instead of requiring the Contractor to correct or resubmit a defective or improper application for payment, to reject the defective or improper portion of the application for payment and pay the remainder of the application for payment that is correct and proper.

Owner, upon written notice to the Contractor, may elect to make payments to the Contractor only by means of Electronic Funds Transfers (EFT) through Automated Clearing House (ACH) payments. If Owner makes this election, the Contractor will be required to arrange to receive EFT/ACH payments.

E.2.2 Contractor shall submit to the Owner's Authorized Representative, an application for each payment and, if required, receipts or other vouchers showing payments for materials and labor, including payments to Subcontractors. Contractor shall include, in its application for payment, a schedule of the percentages of the various parts of the Work completed, based on the Schedule of Values which shall aggregate to the payment application total, and shall include, on the face of each copy thereof, a certificate in substantially the following form:

### **EXHIBIT 1, ATTACHMENT C – GENERAL CONDITIONS**

"I, the undersigned, hereby certify that the above bill is true and correct, and the payment therefore, has not been received.

Signed: \_\_\_\_\_”

E.2.3 Generally, applications for payment will be accepted only for materials that have been installed. Under special conditions, applications for payment for stored materials will be accepted at Owner's sole discretion. Such a payment, if made, will be subject to the following conditions:

- (a) The request for stored material shall be submitted at least thirty (30) Days in advance of the application for payment on which it appears. Applications for payment shall be entertained for major equipment, components or expenditures only.
- (b) The Contractor shall submit applications for payment showing the quantity and cost of the material stored.
- (c) The material shall be stored in a bonded warehouse and Owner's Authorized Representative shall be granted the right to access the material for the purpose of removal or inspection at any time during the Contract Period.
- (d) The Contractor shall name the Owner as co-insured on the insurance policy covering the full value of the property while in the care and custody of the Contractor until it is installed. A certificate noting this coverage shall be issued to the Owner.
- (e) Payments shall be made for materials only. The submitted amount of the application for payment shall be reduced by the cost of transportation and for the cost of an inspector to check the delivery at out of town storage sites. The cost of said inspection shall be borne solely by the Contractor.
- (f) Within sixty (60) Days of the application for payment, the Contractor shall submit evidence of payment covering the material stored.
- (g) Payment for stored materials shall in no way indicate acceptance of the materials or waive any rights under this Contract for the rejection of the Work or materials not in conformance with the Contract Documents.
- (h) All required documentation must be submitted with the respective application for payment.

E.2.4 The Owner reserves the right to withhold all or part of a payment, or may nullify in whole or part any payment previously made, to such extent as may be necessary in the Owner's opinion to protect the Owner from loss because of:

- (a) Work that is defective and not remedied, or that has been demonstrated or identified as failing to conform with the Contract Documents,
- (b) third party claims filed or evidence reasonably indicating that such claims will likely be filed unless security acceptable to the Owner is provided by the Contractor;
- (c) failure of the Contractor to make payments properly to Subcontractors or for labor, materials or equipment (in which case Owner may issue checks made payable jointly to Owner and such unpaid persons under this provision, or directly to Subcontractors and suppliers at any level under Section C.3.2.1);
- (d) reasonable evidence that the Work cannot be completed for the unpaid balance of the Contract Price;
- (e) damage to the Owner or another contractor;

#### **EXHIBIT 1, ATTACHMENT C – GENERAL CONDITIONS**

- (f) reasonable evidence that the Work will not be completed within the Contract Time required by the Contract, and that the unpaid balance would not be adequate to cover actual or liquidated damages for the anticipated delay;
- (g) failure to carry out the Work in accordance with the Contract Documents; or
- (h) assessment of liquidated damages, when withholding is made for offset purposes.

E.2.5 Subject to the provisions of the Contract Documents, the amount of each progress payment shall be computed as follows:

- (a) Take that portion of the Contract Price properly allocable to completed Work as determined by multiplying the percentage completion of each portion of the Work by the share of the total Contract Price allocated to that portion of the Work in the Schedule of Values, less retainage as provided in Section E.5. Pending final determination of cost to the Owner of changes in the Work, amounts not in the dispute may be included even though the Contract Price has not yet been adjusted by Change Order;
- (b) Add that portion of the Contract Price properly allocable to materials and equipment delivered and suitably stored at the site for subsequent incorporation in the completed construction (or, if approved in advance by the Owner pursuant to Section E.2.3, suitably stored off the site at a location agreed upon in writing), less retainage as provided in Section E.5;
- (c) Subtract the aggregate of previous payments made by the Owner; and
- (d) Subtract any amounts for which the Owner's Authorized Representative has withheld or nullified payment as provided in the Contract Documents.

E.2.6 Contractor's applications for payment may not include requests for payment for portions of the Work for which the Contractor does not intend to pay to a Subcontractor or material supplier.

E.2.7 The Contractor warrants to Owner that title to all Work covered by an application for payment will pass to the Owner no later than the time of payment. The Contractor further warrants that upon submittal of an application for payment all Work for which payments are received from the Owner shall be free and clear of liens, claims, security interests or encumbrances in favor of the Contractor, Subcontractors, material suppliers, or other persons or entities making a claim by reason of having provided labor, materials and equipment relating to the Work.

E.2.8 If Contractor disputes any determination by Owner's Authorized Representative with regard to any application for payment, Contractor nevertheless shall continue to prosecute expeditiously the Work. No payment made hereunder shall be or be construed to be final acceptance or approval of that portion of the Work to which such partial payment relates or shall relieve Contractor of any of its obligations hereunder.

### **E.3 PAYROLL CERTIFICATION REQUIREMENT**

Payroll certification is required before payments are made on the Contract. Refer to Section C.2 for this information.

### **E.4 DUAL PAYMENT SOURCES**

Contractor shall not be compensated for Work performed under this Contract from any state agency other than the agency that is a party to this Contract.

### **E.5 RETAINAGE**

E.5.1 Retainage shall be withheld and released in accordance with ORS 279C.550 to 279C.580:

## **EXHIBIT 1, ATTACHMENT C – GENERAL CONDITIONS**



E.5.1.1 Owner may reserve as retainage from any progress payment an amount not to exceed five percent of the payment. As Work progresses, Owner may reduce the amount of the retainage and may eliminate retainage on any remaining monthly Contract payments after 50 percent of the Work under the Contract is completed if, in the Owner's opinion, such Work is progressing satisfactorily. Elimination or reduction of retainage shall be allowed only upon written application by the Contractor, which application shall include written approval of Contractor's surety; except that when the Work is 97-1/2 percent completed the Owner may, at its discretion and without application by the Contractor, reduce the retained amount to 100 percent of the value of the Work remaining to be done. Upon receipt of written application by the Contractor, Owner shall respond in writing within a reasonable time.

E.5.1.2 In accordance with the provisions of ORS 279C.560 and any applicable administrative rules, unless the Owner finds in writing that accepting a bond, security or other instrument described in options (a) or (c) below poses an extraordinary risk that is not typically associated with the bond, security or instrument, the Owner will approve the Contractor's written request:

(a) to be paid amounts which would otherwise have been retained from progress payments where Contractor has deposited acceptable bonds, securities or other instruments of equal value with Owner or in a custodial account or other mutually-agreed account satisfactory to Owner, with an approved bank or trust company to be held in lieu of the cash retainage for the benefit of Owner. Interest or earnings on the bonds, securities or other instruments shall accrue to the Contractor. The Contractor shall execute and provide such documentation and instructions respecting the bonds, securities and other instruments as the Owner may require to protect its interests. To be permissible the bonds, securities and other instruments must be of a character approved by the Director of the Oregon Department of Administrative Services, including but not limited to:

- (i) Bills, certificates, notes or bonds of the United States.
- (ii) Other obligations of the United States or agencies of the United States.
- (iii) Obligations of a corporation wholly owned by the federal government.
- (iv) Indebtedness of the Federal National Mortgage Association.
- (v) General obligation bonds of the State of Oregon or a political subdivision of the State of Oregon.
- (vi) Irrevocable letters of credit issued by an insured institution, as defined in ORS 706.008.

(b) that retainage be deposited in an interest bearing account, established through the State Treasurer for state agencies, in a bank, savings bank, trust company or savings association for the benefit of Owner, with interest from such account accruing to the Contractor; or

(c) that the Contractor be allowed, with the approval of the Owner, to deposit a surety bond for the benefit of Owner, in a form acceptable to Owner, in lieu of all or a portion of funds retained, or to be retained. Such bond and any proceeds therefrom shall be made subject to all claims and liens in the manner and priority as set forth for retainage under ORS 279C.550 to ORS 279C.625.

Where the Owner has accepted the Contractor's election of any of the options above, Owner may recover from Contractor any additional costs incurred through such election by reducing Contractor's final payment. Where the Owner has agreed to Contractor's request to deposit a surety bond under option (c), Contractor shall accept like bonds from Subcontractors and suppliers on the project from which Contractor has required retainage.

E.5.1.3 The retainage held by Owner shall be included in and paid to the Contractor as part of the final payment of the Contract Price. The Owner shall pay to Contractor interest at the rate of one and one-half percent per month on the final payment due Contractor, interest to commence thirty (30) Days after the Work under the Contract has been completed and accepted and to run until the date Contractor shall notify Owner in writing when the Contractor considers the Work complete and Owner shall, within fifteen (15) Days after receiving the written notice, either accept the Work or notify the Contractor of Work yet to be performed on the Contract. If Owner does not within the time allowed notify the Contractor of Work yet to be performed to fulfill contractual obligations, the interest provided by this subsection shall commence to run thirty (30) Days after the end of the 15-Day period.

## **EXHIBIT 1, ATTACHMENT C – GENERAL CONDITIONS**

E.5.1.4 In accordance with the provisions of ORS 279C.560, if the Owner accepts bonds, securities or other instruments deposited as provided in paragraphs (a) and (c) of subsection E.5.1.2, the Owner shall reduce the moneys held as retainage in an amount equal to the value of the bonds, securities and other instruments and pay the amount of the reduction to the Contractor in accordance with ORS 279C.570.

E.5.1.5 Contractor agrees that if Contractor elects to reserve a retainage from any progress payment due to any Subcontractor or supplier, such retainage shall not exceed five percent of the payment, and such retainage withheld from Subcontractors and suppliers shall be subject to the same terms and conditions stated in Subsection E.5 as apply to Owner's retainage from any progress payment due to Contractor. Provided, however, if in accordance with the provisions of ORS 279C.560 the Contractor has deposited bonds, securities or other instruments or has elected to have the Owner deposit accumulated retainage in an interest-bearing account, the Contractor shall comply with the provisions of ORS 701.435 respecting the deposit of bonds, securities or other instruments by Subcontractors and suppliers and the sharing of interest earnings with Subcontractors and suppliers.

E.5.2 As provided in subsections C.2.2 and C.2.3, additional retainage in the amount of 25% of amounts earned shall be withheld and released in accordance with ORS 279C.845(7) when the Contractor fails to file certified statements as required by section C.2.1.

## **E.6 FINAL PAYMENT**

E.6.1 Upon completion of all the Work under this Contract, the Contractor shall notify the Owner's Authorized Representative, in writing, that Contractor has completed Contractor's part of the Contract and shall request final payment. Upon receipt of such notice the Owner's Authorized Representative will inspect the Work, and if acceptable, submit to the Owner a recommendation as to acceptance of the completed Work and as to the final estimate of the amount due the Contractor. If the Work is not acceptable, Owner will notify Contractor within fifteen (15) Days of Contractor's request for final payment. Upon approval of this final estimate by the Owner and compliance by the Contractor with provisions in Section K. 3 AFFIDAVIT/RELEASE OF LIENS AND CLAIMS, and other provisions as may be applicable, the Owner shall pay to the Contractor all monies due under the provisions of these Contract Documents.

E.6.2 Neither final payment nor any remaining retained percentage shall become due until the Contractor submits to the Owner's Authorized Representative (1) a notarized affidavit/release of liens and claims in a form satisfactory to Owner that states that payrolls, bills for materials and equipment, and other indebtedness connected with the Work for which the Owner or the Owner's property might be responsible or encumbered (less amounts withheld by Owner) have been paid or otherwise satisfied, (2) a certificate evidencing that insurance required by the Contract Documents to remain in force after final payment is currently in effect and will not be canceled or allowed to expire until at least thirty (30) Days' prior written notice has been given to the Owner, (3) a written statement that the Contractor knows of no substantial reason that the insurance will not be renewable to cover the period required by the Contract Documents, (4) consent of surety, if any, to final payment and (5), if required by the Owner, other data establishing payment or satisfaction of obligations, such as receipts, releases and waivers of liens, claims, security interests or encumbrances arising out of the Contract, to the extent and in such form as may be designated by the Owner. If a Subcontractor refuses to furnish a release or waiver required by the Owner, the Contractor may furnish a bond satisfactory to the Owner to indemnify the Owner against such lien. If such lien remains unsatisfied after payments are made, the Contractor shall refund to the Owner all money that the Owner may be compelled to pay in discharging such lien, including all costs and reasonable attorneys' fees.

E.6.3 Acceptance of final payment by the Contractor, a Subcontractor or material supplier shall constitute a waiver of claims by that payee except those previously made in writing and identified by that payee as unsettled at the time of final application for payment.

## **SECTION F *JOB SITE CONDITIONS***

### **F.1 USE OF PREMISES**

#### **EXHIBIT 1, ATTACHMENT C – GENERAL CONDITIONS**

Contractor shall confine equipment, storage of materials and operation of Work to the limits indicated by Contract Documents, law, ordinances, permits or directions of the Owner's Authorized Representative. Contractor shall follow the Owner's Authorized Representative's instructions regarding use of premises, if any.

## **F.2 PROTECTION OF WORKERS, PROPERTY, AND THE PUBLIC**

F.2.1 Contractor shall maintain continuous and adequate protection of all of the Work from damage, and shall protect the Owner's Authorized Representative, Owner's workers and property from injury or loss arising in connection with this Contract. Contractor shall remedy acceptably to the Owner, any damage, injury, or loss, except such as may be directly due to errors in the Contract Documents or caused by authorized representatives or personnel of the Owner. Contractor shall adequately protect adjacent property as provided by law and the Contract Documents.

F.2.2 Contractor shall take all necessary precautions for the safety of all personnel on the job site, and shall comply with the Contract Documents and all applicable provisions of federal, state and municipal safety laws and building codes to prevent accidents or injury to persons on, about or adjacent to the premises where the Work is being performed. Contractor shall erect and properly maintain at all times, as required by the conditions and progress of the Work, all necessary safeguards for protection of workers and the public against any hazards created by construction. Contractor shall designate a responsible employee or associate on the Work site, whose duty shall be the prevention of accidents. The name and position of the person designated shall be reported to the Owner's Authorized Representative. The Owner's Authorized Representative has no responsibility for Work site safety. Work site safety is the responsibility of the Contractor.

F.2.3 Contractor shall not enter upon private property without first obtaining permission from the property owner or its duly authorized representative. Contractor shall be responsible for the preservation of all public and private property along and adjacent to the Work contemplated under the Contract and shall use every precaution necessary to prevent damage thereto. In the event the Contractor damages any property, the Contractor shall at once notify the property owner and make, or arrange to make, full restitution. Contractor shall report, immediately in writing, to the Owner's Authorized Representative, all pertinent facts relating to such property damage and the ultimate disposition of the claim for damage.

F.2.4 Contractor is responsible for protection of adjacent work areas including impacts brought about by activities, equipment, labor, utilities, and materials on the site.

F.2.5 Contractor shall at all times direct its activities in such a manner as to minimize adverse effects on the environment. Handling of all materials will be conducted so no release will occur that may pollute or become hazardous.

F.2.6 In an emergency affecting the safety of life or of the Work or of adjoining property, the Contractor, without special instruction or authorization from the Owner's Authorized Representative, shall act reasonably to prevent threatened loss or injury, and shall so act, without appeal, if instructed by the Owner's Authorized Representative. Any compensation claimed by the Contractor on account of emergency work shall be determined in accordance with Section D.

## **F.3 CUTTING AND PATCHING**

F.3.1 Contractor shall be responsible for coordinating all cutting, fitting, or patching of the Work to make its several parts come together properly and fit to receive or be received by work of other contractors or Subcontractors shown upon, or reasonably implied by, the Contract Documents.

F.3.2 Contractor shall be responsible for restoring all cut, fitted, or patched surfaces to an original condition; provided, however, that if a different condition is specified in the Contract Documents, then Contractor shall be responsible for restoring such surfaces to the condition specified in the Contract Documents.

### **EXHIBIT 1, ATTACHMENT C – GENERAL CONDITIONS**

#### **F.4 CLEANING UP**

From time to time as may be ordered by the Owner the Contractor shall, at its own expense, clean up and remove all refuse and unused materials of any kind resulting from the Work. If Contractor fails to do so within twenty-four hours after notification by the Owner the work may be done by others and the cost charged to the Contractor and deducted from payment due the Contractor.

#### **F.5 ENVIRONMENTAL CONTAMINATION**

F.5.1 Contractor will be held responsible for and shall indemnify, defend (with counsel of Owner's choice) and hold harmless Owner from and against any costs, expenses, damages, claims, and causes of action, (including attorney fees), or any of them, resulting from all spills, releases, discharges, leaks and disposal of environmental pollution, including storage, transportation, and handling during the performance of the Contract which occur as a result of, or are contributed by, the negligence or actions of Contractor or its personnel, agents, or Subcontractors or any failure to perform in accordance with the Contract Documents (except to the extent otherwise void under ORS 30.140). Nothing in this section F.5.1 shall limit Contractor's responsibility for obtaining insurance coverages required under Section G.3 of these General Conditions, and Contractor shall take no action that would void or impair such coverages.

F.5.1.1 Contractor agrees to promptly dispose of such spills, releases, discharge or leaks to the satisfaction of Owner and proper regulatory agencies in a manner that complies with applicable federal, state, and local laws and regulations. Cleanup shall be at no cost to the Owner and be performed by properly qualified personnel.

F.5.1.2 Contractor shall obtain the Owner's written consent prior to bringing onto the Work site any (i) environmental pollutants or (ii) hazardous substances or materials, as the same or reasonably similar terms are used in any applicable federal, state, or local statutes, rules or ordinances. Notwithstanding such written consent from the Owner, the Contractor, at all times, shall:

- (a) properly handle, use and dispose of all environmental pollutants and hazardous substances or materials brought onto the Work site, in accordance with all applicable federal, state, or local statutes, rules, or ordinances;
- (b) be responsible for any and all spills, releases, discharges, or leaks of (or from) environmental pollutants or hazardous substances or materials which Contractor has brought onto the Work site; and
- (c) promptly clean up, without cost to the Owner, such spills, releases, discharges, or leaks to the Owner's satisfaction and in compliance with all applicable federal, state, or local statutes, rules or ordinances.

F.5.2 Contractor shall report all reportable quantity releases to applicable federal, state, and local regulatory and emergency response agencies. Reportable quantities are found in 40 CFR Part 302, Table 302.4 for hazardous substances and in OAR 340-142-0050 for all products addressed therein. Upon discovery, regardless of quantity, Contractor must telephonically report all releases to the Owner. A written follow-up report shall be submitted to Owner within 48 hours of the telephonic report. Such written report shall contain, as a minimum:

- (a) Description of items released (identity, quantity, manifest no., and all other documentation required by law.)
- (b) Whether amount of items released is EPA/DEQ reportable, and, if so, when it was reported.
- (c) Exact time and location of release, including a description of the area involved.
- (d) Containment procedures initiated.
- (e) Summary of communications about the release Contractor has had with members of the press or State officials other than Owner.

#### **EXHIBIT 1, ATTACHMENT C – GENERAL CONDITIONS**

- (f) Description of cleanup procedures employed or to be employed at the site, including disposal location of spill residue.
- (g) Personnel injuries, if any, resulting from, or aggravated by, the release.

## **F.6 ENVIRONMENTAL CLEAN-UP**

F.6.1 Unless disposition of environmental pollution is specifically a part of this Contract, or was caused by the Contractor (reference F.5 Environmental Contamination), Contractor shall immediately notify Owner of any hazardous substance(s) which Contractor discovers or encounters during performance of the Work required by this Contract. "Hazardous substance(s)" means any hazardous, toxic and radioactive materials and those substances defined as "hazardous substances," "hazardous materials," "hazardous wastes," "toxic substances," or other similar designations in any federal, state, or local law, regulation, or ordinance, including without limitation asbestos, polychlorinated biphenyl (PCB), or petroleum, and any substances, materials or wastes regulated in 40 CFR, Part 261 and defined as hazardous in 40 CFR S 261.3. In addition to notifying Owner of any hazardous substance(s) discovered or encountered, Contractor shall immediately cease working in any particular area of the project where a hazardous substance(s) has been discovered or encountered if continued work in such area would present a risk or danger to the health or well being of Contractor's or any Subcontractor's work force.

F.6.2 Upon being notified by Contractor of the presence of hazardous substance(s) on the project site, Owner shall arrange for the proper disposition of such hazardous substance(s).

## **F.7 FORCE MAJEURE**

A party to this Contract shall not be held responsible for delay or default due to Force Majeure acts, events or occurrences unless they could have been avoided by the exercise of reasonable care, prudence, foresight, and diligence by that party. The Owner may terminate this Contract upon written notice after determining that delay or default caused by Force Majeure acts, events or occurrences will reasonably prevent successful performance of the Contract.

## **SECTION G *INDEMNITY, BONDING, AND INSURANCE***

### **G.1 RESPONSIBILITY FOR DAMAGES / INDEMNITY**

G.1.1 Contractor shall be responsible for all damage to property, injury to persons, and loss, expense, inconvenience, and delay that may be caused by, or result from, the carrying out of the Work to be done under this Contract, or from any act, omission or neglect of the Contractor, its Subcontractors, personnel, or agents.

G.1.2 To the fullest extent permitted by law, Contractor shall indemnify, defend (with counsel approved by Owner) and hold harmless the Owner, Owner's Authorized Representative, Architect/Engineer, Architect/Engineer's consultants, and their respective officers, directors, agents, employees, partners, members, stockholders and affiliated companies (collectively "Indemnitees") from and against all liabilities, damages, losses, claims, expenses (including reasonable attorney fees), demands and actions of any nature whatsoever which arise out of, result from or are related to, (a) any damage, injury, loss, expense, inconvenience or delay described in this Section G.1.2, (b) any accident or occurrence which happens or is alleged to have happened in or about the project site or any place where the Work is being performed, or in the vicinity of either, at any time prior to the time the Work is fully completed in all respects, (c) any failure of the Contractor to observe or perform any duty or obligation under the Contract Documents which is to be observed or performed by the Contractor, or any breach of any agreement, representation or warranty of the Contractor contained in the Contract Documents or in any subcontract, (d) the negligent acts or omissions of the Contractor, a Subcontractor or anyone directly or indirectly employed by them or any one of them or anyone for whose acts they may be liable, regardless of whether or not such claim, damage, loss or expense is caused in part by a party indemnified hereunder (except to the extent otherwise void under ORS 30.140), and (e) any lien filed upon the project or bond claim in connection with the Work. Such obligation shall

### **EXHIBIT 1, ATTACHMENT C – GENERAL CONDITIONS**

not be construed to negate, abridge, or reduce other rights or obligations of indemnity which would otherwise exist as to a party or person described in this Section G.1.2.

G.1.3 In claims against any person or entity indemnified under this Section G.1.2 by an employee of the Contractor, a Subcontractor, anyone directly or indirectly employed by them or anyone for whose acts they may be liable, the indemnification obligation under Section G.1.2 shall not be limited by a limitation on amount or type of damages, compensation or benefits payable by or for the Contractor or a Subcontractor under workers' compensation acts, disability benefit acts or other employee benefit acts.

## **G.2 PERFORMANCE AND PAYMENT SECURITY; PUBLIC WORKS BOND**

G.2.1 When the Contract Price is \$100,000 or more (or \$50,000 or more in the case of Contracts for highways, bridges and other transportation projects) the Contractor shall furnish and maintain in effect at all times during the Contract Period, a performance bond in a sum equal to the Contract Price, and a separate payment bond also in a sum equal to the Contract Price. The bonds may be required if the Contract Price is less than the above thresholds, if required by the Contract Documents.

G.2.2 Bond forms furnished by the Owner and notarized by awarded Contractor's surety company authorized to do business in Oregon are the only acceptable forms of performance and payment security, unless otherwise specified in the Contract Documents.

G.2.3 Before starting Work the Contractor shall file with the Construction Contractors Board, and maintain in full force and effect, the separate public works bond required by Oregon Laws 2005, Chapter 360, and OAR 839-025-0015, unless otherwise exempt under those provisions. The Contractor shall also include in every subcontract a provision requiring the Subcontractor to have a public works bond filed with the Construction Contractors Board before starting Work, unless otherwise exempt, and shall verify that the Subcontractor has filed a public works bond before permitting the Subcontractor to start Work.

## **G.3 INSURANCE**

G.3.1 Primary Coverage: Insurance carried by Contractor under this Contract shall be the primary coverage, and the Owner's insurance is excess and solely for damages or losses for which the Owner is responsible. The coverages indicated are minimums unless otherwise specified in the Contract Documents.

G.3.2 Workers' Compensation: All employers, including Contractor, that employ subject workers who work under this contract in the State of Oregon shall comply with ORS 656.017 and provide the required Workers' Compensation coverage, unless such employers are exempt under ORS 656.126. This shall include Employer's Liability Insurance with coverage limits of not less than \$100,000 for each accident. Contractors who perform the Work without the assistance or labor of any employee need not obtain such coverage if the Contractor certifies so in writing. Contractor shall ensure that each of its Subcontractors complies with these requirements. The Contractor shall require proof of such Workers' Compensation by receiving and keeping on file a certificate of insurance from each Subcontractor or anyone else directly employed by either the Contractor or its Subcontractors.

G.3.3 Builder's Risk Insurance:

G.3.3.1 Builder's Risk: During the term of this Contract, for new construction the Contractor shall obtain and keep in effect Builder's Risk insurance on an all risk form, including earthquake and flood, for an amount equal to the full amount of the Contract. Any deductible shall not exceed \$50,000 for each loss, except the earthquake and flood deductible shall not exceed 2 percent of each loss or \$50,000, whichever is more. The policy will include as loss payees the Owner, the Contractor and its Subcontractors as their interests may appear.

G.3.3.2 Builder's Risk Installation Floater: For other than new construction the Contractor shall obtain and keep in effect during the term of this Contract, a Builder's Risk Installation Floater for coverage of the Contractor's labor, materials and equipment to be used for completion of the Work performed under this Contract. The minimum

## **EXHIBIT 1, ATTACHMENT C – GENERAL CONDITIONS**

amount of coverage to be carried shall be equal to the full amount of the Contract. This insurance shall include as loss payees the State of Oregon, the Owner, the Contractor and its Subcontractors as their interests may appear.

G.3.3.3 Such insurance shall be maintained until Owner has occupied the facility.

G.3.3.4 A loss insured under the Builder's Risk insurance shall be adjusted by the Owner and made payable to the Owner for the insureds, as their interests may appear. The Contractor shall pay Subcontractors their just shares of insurance proceeds received by the Contractor, and by appropriate agreements, written where legally required for validity, shall require Subcontractors to make payments to their Sub-subcontractors in similar manner. The Owner shall have power to adjust and settle a loss with insurers.

G.3.4 Liability Insurance:

G.3.4.1 Commercial General Liability: Contractor shall obtain, at Contractor's expense, and keep in effect during the term of this Contract, Commercial General Liability Insurance covering bodily injury and property damage in a form and with coverages that are satisfactory to the State. This insurance shall include personal injury liability, products and completed operations, and contractual liability coverage for the indemnity provided under this Contract (to the extent contractual liability coverage for the indemnity is available in the marketplace), and shall be issued on an occurrence basis. Contractor shall provide proof of insurance of not less than the following amounts:

Amounts not less than the amounts listed in the following schedule:

<u>Combined single limit per occurrence:</u>	\$1,000,000
<u>Aggregate limit for all claims per occurrence:</u>	\$3,000,000

Property Damage:

Amounts not less than the amounts listed in the following schedule:

Combined single limit per occurrence shall not be less than the following amounts listed in the following schedule:  
\$100,000.

Aggregate limits for all claims per occurrence shall not be less than the following amounts listed in the following schedule: \$500,000.

G.3.4.2 Automobile Liability: Contractor shall obtain, at Contractor's expense, and keep in effect during the term of this Contract, Automobile Liability Insurance covering owned, non-owned and/or hired vehicles, as applicable. The coverage may be written in combination with the Commercial General Liability Insurance. Contractor shall provide proof of insurance of not less than the following amounts:

Bodily Injury/Death:

Amounts not less than the amounts listed in the following schedule:

Combined single limit per occurrence:  
\$1,500,000

Aggregate limit for all claims per occurrence: \$3,000,000

Property Damage: \$100,000

G.3.4.3 "Tail" Coverage: If any of the required liability insurance is arranged on a "claims made" basis, "tail" coverage will be required at the completion of this Contract for a duration of 24 months or the maximum time period

**EXHIBIT 1, ATTACHMENT C – GENERAL CONDITIONS**

available in the marketplace if less than 24 months. Contractor will be responsible for furnishing certification of "tail" coverage as described or continuous "claims made" liability coverage for 24 months following Final Completion. Continuous "claims made" coverage will be acceptable in lieu of "tail" coverage, provided its retroactive date is on or before the effective date of this Contract. This will be a condition of the final acceptance of Work or services and related warranty (if any).

G.3.5 Additional Insured: The liability insurance coverage, except Professional Liability if included, required for performance of this Contract shall include the State of Oregon, its departments, divisions, officers, and employees, as Additional Insureds but only with respect to the Contractor's activities to be performed under this Contract.

If Contractor cannot obtain an insurer to name the State of Oregon, its departments, divisions, officers and employees as Additional Insureds, Contractor shall obtain at Contractor's expense, and keep in effect during the term of this Contract, Owners and Contractors Protective Liability Insurance, naming the State of Oregon, its departments, divisions, officers and employees as Named Insureds with not less than a \$1,500,000.00 limit per occurrence. This policy must be kept in effect for 12 months following Final Completion. As evidence of coverage, Contractor shall furnish the actual policy to Owner prior to its issuance of a Notice to Proceed.

G.3.6 Notice of Cancellation or Change: There shall be no cancellation, material change, potential exhaustion of aggregate limits or intent not to renew insurance coverages without thirty (30) Days' written notice from the Contractor or its insurer(s) to the Owner. Any failure to comply with the reporting provisions of this insurance, except for the potential exhaustion of aggregate limits, shall not affect the coverages provided to the State of Oregon, its Owner and their divisions, officers, and employees.

G.3.7 Certificate(s) of Insurance: As evidence of the insurance coverage required by this Contract, the Contractor shall furnish certificate(s) of insurance to the Owner prior to its issuance of a Notice to Proceed. The certificate(s) will specify all of the parties who are Additional Insureds or Loss Payees. Insurance coverage required under this Contract shall be obtained from insurance companies or entities acceptable to the Owner that are allowed to provide such insurance under Oregon law. Eligible insurers include admitted insurers that have been issued a certificate of authority from the Oregon Department of Consumer and Business Services authorizing them to do an insurance business in the state of Oregon, and certain non-admitted surplus lines insurers that satisfy the requirements of applicable Oregon law and are approved by the Owner. The certificates will also specify that there shall be no cancellation, material change, potential exhaustion of aggregate limits or intent not to renew insurance coverages without thirty (30) Days' written notice from the insurer(s) to the Owner. To the extent Certificates of Insurance contain words to the effect that Contractor shall "endeavor to send notice of cancellation" or similar language, Contractor shall require its insurer to send such notice by making sure that the words "endeavor to" or similar words are removed from the Certificate. The Contractor shall be financially responsible for all deductibles, self-insured retentions and/or self-insurance included hereunder. Any deductible, self-insured retention and/or self-insurance in excess of \$50,000 shall be approved by the Owner in writing prior to issuance of a Notice to Proceed and is subject to Owner's approval.

## **SECTION H**

### ***SCHEDULE OF WORK***

#### **H.1 CONTRACT PERIOD**

H.1.1 **Time is of the essence on this Contract.** The Contractor shall at all times carry on the Work diligently, without delay and punctually fulfill all requirements herein. Contractor shall commence Work on the site within fifteen (15) Days of Notice to Proceed, unless directed otherwise.

H.1.2 Unless specifically extended by Change Order, all Work shall be complete by the date contained in the Contract Documents. The Owner shall have the right to accelerate the completion date of the Work, which may require the use of overtime. Such accelerated Work schedule shall be an acceleration in performance of Work under Section D.1.2 (f) and shall be subject to the Change Order process of Section D.1.

## **EXHIBIT 1, ATTACHMENT C – GENERAL CONDITIONS**



H.1.3 The Owner shall not waive any rights under the Contract by permitting the Contractor to continue or complete the Work or any part of it after the date described in Section H.1.2 above.

## **H.2 SCHEDULE**

H.2.1 Contractor shall provide, by or before the pre-construction conference, a detailed schedule for review and acceptance by the Owner. The submitted schedule must illustrate Work by significant project components, significant labor trades, long lead items, broken down by building and/or floor where applicable. Each schedule item shall account for no greater than 5 % of the monetary value of the project or 5 % of the available Contract Time. Schedules with activities of less than one day or valued at less than 1% of the Contract will be considered too detailed and will not be accepted. Schedules lacking adequate detail, or unreasonably detailed, will be rejected. Included within the schedule are the following: Notice to Proceed, Substantial Completion, and Final Completion. Schedules will be updated monthly and submitted with the monthly payment application. Acceptance of the Schedule by the Owner does not constitute agreement by the Owner, as to the Contractor's sequencing, means, methods, or allocated Contract Time. Any positive difference between the Contractor's scheduled completion and the Contract completion date is float owned by the Owner. Owner reserves the right to negotiate the float if it is deemed to be in Owner's best interest to do so. In no case shall the Contractor make a request for additional compensation for delays if the Work is completed within the Contract Time but after Contractor's scheduled completion.

## **H.3 PARTIAL OCCUPANCY OR USE**

H.3.1 The Owner may occupy or use any completed or partially completed portion of the Work at any stage, provided such occupancy or use is consented to by public authorities having jurisdiction over the Work. Such partial occupancy or use may commence whether or not the portion is substantially complete, provided the Owner and Contractor have reasonably accepted in writing the responsibilities assigned to each of them for payments, retainage, if any, security, insurance or self-insurance, maintenance, heat, utilities, and damage to the Work, and have agreed in writing concerning the period for correction of the Work and commencement of warranties required by the Contract Documents with respect to such portion of the Work. Approval by the Contractor to partial occupancy or use shall not be unreasonably withheld. Immediately prior to such partial occupancy or use, the Owner and Contractor shall jointly inspect the area to be occupied or portion of the Work to be used in order to determine and record the condition of the Work. Partial occupancy or use of a portion or portions of the Work shall not constitute acceptance of Work not complying with the requirements of the Contract Documents.

## **SECTION I *CORRECTION OF WORK***

### **I.1 CORRECTION OF WORK BEFORE FINAL PAYMENT**

The Contractor warrants to the Owner that materials and equipment furnished under the Contract will be of good quality and new unless otherwise required or permitted by the Contract Documents, that the Work will be free from defects, and that the Work will conform to the requirements of the Contract Documents. Work failing to conform to these requirements shall be deemed defective. Contractor shall promptly remove from the premises and replace all defective materials and equipment as determined by the Owner's Authorized Representative, whether incorporated in the Work or not. Removal and replacement shall be without loss or expense to the Owner, and Contractor shall bear the cost of repairing all Work destroyed or damaged by such removal or replacement. Contractor shall be allowed a period of no longer than sixty (60) days for completion of defective (punch list) work, unless otherwise agreed. At the end of that period, or earlier if requested by the Contractor, Owner shall arrange for inspection of the Work by the Architect/Engineer. Should the Work not be complete, and all corrections made, the costs for all subsequent re-inspections shall be borne by the Contractor. If Contractor fails to complete the punch list work within the above time period, without affecting Contractor's obligations Owner may perform such work and Contractor shall reimburse Owner all costs of the same within thirty (30) days after demand.

### **I.2 WARRANTY WORK**

#### **EXHIBIT 1, ATTACHMENT C – GENERAL CONDITIONS**

I.2.1 Neither the final certificate of payment nor any provision of the Contract Documents shall relieve the Contractor from responsibility for defective Work and, unless a longer period is specified, Contractor shall correct all defects that appear in the Work within a period of one year from the date of issuance of the written notice of Substantial Completion by the Owner except for latent defects which will be remedied by the Contractor at any time they become apparent.

The Owner shall give Contractor notice of defects with reasonable promptness. Contractor shall perform such warranty work within a reasonable time after Owner's demand. If Contractor fails to complete the warranty work within such period as Owner determines reasonable, or at any time in the event of warranty work consisting of emergency repairs, without affecting Contractor's obligations, Owner may perform such work and Contractor shall reimburse Owner all costs of the same within thirty (30) Days after demand.

I.2.2 This provision does not negate guarantees or warranties for periods longer than one year including without limitation such guarantees or warranties required by other sections of the Contract Documents for specific installations, materials, processes, equipment or fixtures.

I.2.3 In addition to Contractor's warranty, manufacturer's warranties shall pass to the Owner and shall not take effect until affected Work has been accepted in writing by the Owner's Authorized Representative.

I.2.4 The one-year period for correction of Work shall be extended with respect to portions of Work performed after Substantial Completion by the period of time between Substantial Completion and the actual performance of the Work, and shall be extended by corrective Work performed by the Contractor pursuant to this Section, as to the Work corrected. The Contractor shall remove from the site portions of the Work which are not in accordance with the requirements of the Contract Documents and are neither corrected by the Contractor nor accepted by the Owner.

I.2.5 Nothing contained in this Section I.2 shall be construed to establish a period of limitation with respect to other obligations which the Contractor might have under the Contract Documents. Establishment of the period for correction of Work as described in this Section I.2 relates only to the specific obligation of the Contractor to correct the Work, and has no relationship to the time within which the obligation to comply with the Contract Documents may be sought to be enforced, nor to the time within which proceedings may be commenced to establish the Contractor's liability with respect to the Contractor's obligations other than specifically to correct the Work.

I.2.6 If the Owner prefers to accept Work which is not in accordance with the requirements of the Contract Documents, the Owner may do so instead of requiring its removal and correction, in which case the Contract Price will be reduced as appropriate and equitable. Such adjustment shall be effected whether or not final payment has been made.

## **SECTION J**

### ***SUSPENSION AND/OR TERMINATION OF THE WORK***

#### **J.1 OWNER'S RIGHT TO SUSPEND THE WORK**

J.1.1 The Owner and/or the Owner's Authorized Representative has the authority to suspend portions or all of the Work due to the following causes:

- (a) Failure of the Contractor to correct unsafe conditions;
- (b) Failure of the Contractor to carry out any provision of the Contract;
- (c) Failure of the Contractor to carry out orders;
- (d) Conditions, in the opinion of the Owner's Authorized Representative, which are unsuitable for performing the Work;

#### **EXHIBIT 1, ATTACHMENT C – GENERAL CONDITIONS**

- (e) Time required to investigate differing site conditions;
- (f) Any reason considered to be in the public interest.

J.1.2 The Owner shall notify Contractor and the Contractor's Surety in writing of the effective date and time of the suspension and shall notify Contractor and its surety in writing to resume Work.

## **J.2 CONTRACTOR'S RESPONSIBILITIES**

J.2.1 During the period of the suspension, Contractor is responsible to continue maintenance at the project just as if the Work were in progress. This includes, but is not limited to, protection of completed Work, maintenance of access, protection of stored materials, temporary facilities, and clean-up.

J.2.2 When the Work is recommenced after the suspension, the Contractor shall replace or renew any Work damaged during the suspension, remove any materials or facilities used as part of temporary maintenance, and complete the project in every respect as though its prosecution had been continuous and without suspension.

## **J.3 COMPENSATION FOR SUSPENSION**

J.3.1 Depending on the reason for suspension of the Work, the Contractor or the Owner may be due compensation by the other party. If the suspension was required due to acts or omissions of Contractor, the Owner may assess the Contractor actual costs of the suspension in terms of administration, remedial work by the Owner's forces or another contractor to correct the problem associated with the suspension, rent of temporary facilities, and other actual costs related to the suspension. If the suspension was caused by acts or omissions of the Owner, the Contractor shall be due compensation which shall be defined using Section D, Changes in Work. If the suspension was required through no fault of the Contractor or the Owner, neither party owes the other for the impact.

## **J.4 OWNER'S RIGHT TO TERMINATE CONTRACT**

J.4.1 The Owner may, without prejudice to any other right or remedy, and after giving Contractor seven (7) Days' written notice and an opportunity to cure, terminate the Contract in whole or in part under the following conditions:

- (a) If Contractor should voluntarily or involuntarily, seek protection under the United States Bankruptcy Code and Contractor as debtor-in-possession or the Trustee for the estate fails to assume the Contract within a reasonable time;
- (b) If Contractor should make a general assignment for the benefit of Contractor's creditors;
- (c) If a receiver should be appointed on account of Contractor's insolvency;
- (d) If Contractor should repeatedly refuse or fail to supply an adequate number of skilled workers or proper materials to carry on the Work as required by the Contract Documents, or otherwise fail to perform the Work in a timely manner;
- (e) If Contractor should repeatedly fail to make prompt payment to Subcontractors or for material or labor, or should disregard laws, ordinances or the instructions of the Owner or its Authorized Representative; or
- (f) If Contractor is otherwise in material breach of any part of the Contract.

J.4.2 At any time that any of the above occurs, Owner may exercise all rights and remedies available to Owner at law or in equity, and in addition, Owner may take possession of the premises and of all materials and appliances and finish the Work by whatever method it may deem expedient. In such case, the Contractor shall not be entitled to

### **EXHIBIT 1, ATTACHMENT C – GENERAL CONDITIONS**

receive further payment until the Work is completed. If the Owner's cost of finishing the Work exceeds the unpaid balance of the Contract Price, Contractor shall pay the difference to the Owner.

#### **J.5 TERMINATION FOR CONVENIENCE**

J.5.1 Owner may terminate the Contract in whole or in part whenever Owner determines that termination of the Contract is in the best interest of the public.

J.5.2 The Owner will provide the Contractor with seven (7) Days' prior written notice of a termination for public convenience. After such notice, the Contractor shall provide the Owner with immediate and peaceful possession of the premises and materials located on and off the premises for which the Contractor received progress payment under Section E. Compensation for Work terminated by the Owner under this provision will be according to Section E. In no circumstance shall Contractor be entitled to lost profits for Work not performed due to termination.

#### **J.6 ACTION UPON TERMINATION**

J.6.1 Upon receiving a notice of termination, and except as directed otherwise by the Owner, Contractor shall immediately cease placing further subcontracts or orders for materials, services, or facilities. In addition, Contractor shall terminate all subcontracts or orders to the extent they relate to the Work terminated and, with the prior written approval of the Owner, settle all outstanding liabilities and termination settlement proposals arising from the termination of subcontracts and orders.

J.6.2 As directed by the Owner, Contractor shall upon termination transfer title and deliver to the Owner all Record Documents, information, and other property that, if the Contract had been completed, would have been required to be furnished to the Owner.

### **SECTION K**

#### ***CONTRACT CLOSE OUT***

#### **K.1 RECORD DOCUMENTS**

As a condition of final payment (refer also to section E.6), Contractor shall comply with the following: Contractor shall provide to Owner's Authorized Representative, Record Documents of the entire project. Record Documents shall depict the project as constructed and shall reflect each and every change, modification, and deletion made during the construction. Record Documents are part of the Work and shall be provided prior to the Owner's issuance of final payment. Record Documents include all modifications to the Contract Documents unless otherwise directed.

#### **K.2 OPERATION AND MAINTENANCE MANUALS**

As part of the Work, Contractor shall submit two completed operation and maintenance manuals ("O & M Manuals") for review by the Owner's Authorized Representative prior to submission of any pay request for more than 75% of the Work. No payments beyond 75% will be made by the Owner until the O & M Manuals have been received. The O & M Manuals shall contain a complete set of all submittals, all product data as required by the specifications, training information, phone list of consultants, manufacturers, installer and suppliers, manufacturer's printed data, record and shop drawings, schematic diagrams of systems, appropriate equipment indices, warranties and bonds. The Owner's Authorized Representative shall review and return one O & M Manual for any modifications or additions required. Prior to submission of its final pay request, Contractor shall deliver three (3) complete and approved sets of O & M Manuals to the Owner's Authorized Representative.

#### **K.3 AFFIDAVIT/RELEASE OF LIENS AND CLAIMS**

As a condition of final payment, the Contractor shall submit to the Owner's Authorized Representative a notarized affidavit/release of liens and claims form, in a form satisfactory to Owner, which states that all

#### **EXHIBIT 1, ATTACHMENT C – GENERAL CONDITIONS**

Subcontractors and suppliers have been paid in full, all disputes with property owners have been resolved, all obligations on the project have been satisfied, all monetary claims and indebtedness have been paid, and that, to the best of the Contractor's knowledge, there are no claims of any kind outstanding against the project. The Contractor shall indemnify, defend (with counsel of Owner's choice) and hold harmless the Owner from all claims for labor and materials finished under this Contract. The Contractor shall furnish complete and valid releases or waivers, satisfactory to the Owner, of all liens arising out of or filed in connection with the Work.

#### **K.4 COMPLETION NOTICES**

K.4.1 Contractor shall provide Owner notice of both Substantial and Final Completion. The certificate of Substantial Completion shall state the date of Substantial Completion, the responsibilities of the Owner and Contractor for security, maintenance, heat, utilities, damage to the Work and insurance, and the time within which the Contractor shall finish all items on the punchlist accompanying the Certificate. Both completion notices must be signed by the Contractor and the Owner to be valid. The Owner shall provide the final signature on the notices. The notices shall take effect on the date they are signed by the Owner.

K.4.2 Substantial Completion of a facility with operating systems (e.g., mechanical, electrical, HVAC) shall be that degree of completion that has provided a minimum of thirty (30) continuous Days of successful, trouble-free operation, which period shall begin after all performance and acceptance testing has been successfully demonstrated to the Owner's Authorized Representative. All equipment contained in the Work, plus all other components necessary to enable the Owner to operate the facility in the manner that was intended, shall be complete on the Substantial Completion date. The Contractor may request that a punch list be prepared by the Owner's Authorized Representative with submission of the request for the Substantial Completion notice.

#### **K.5 TRAINING**

As part of the Work, and prior to submission of the request for final payment, the Contractor shall schedule with the Owner's Authorized Representative, training sessions for all equipment and systems, as required in the individual specifications sections. Contractor shall schedule training sessions at least. Training shall be a formal session, held after the equipment and/or system is completely installed and operational in its normal operating environment.

#### **K.6 EXTRA MATERIALS**

As part of the Work, Contractor shall provide spare parts, extra maintenance materials, and other materials or products in the quantities specified in the specifications, prior to final payment. Delivery point for extra materials shall be designated by the Owner's Authorized Representative.

#### **K.7 ENVIRONMENTAL CLEAN-UP**

As part of the Final Completion notice, or as a separate written notice submitted with or before the notice of Final Completion, the Contractor shall notify the Owner that all environmental pollution clean-up which was performed as a part of this Contract has been disposed of in accordance with all applicable rules, regulations, laws, and statutes of all agencies having jurisdiction over such environmental pollution. The notice shall reaffirm the indemnification given under Section F.5.1 above.

#### **K.8 CERTIFICATE OF OCCUPANCY**

The Contractor shall not be granted Final Completion or receive final payment if the Owner has not received an unconditioned certificate of occupancy from the appropriate state and/or local building officials, unless failure to obtain an unconditional certificate of occupancy is due to the fault or neglect of Owner.

#### **K.9 OTHER CONTRACTOR RESPONSIBILITIES**

### **EXHIBIT 1, ATTACHMENT C – GENERAL CONDITIONS**

The Contractor shall be responsible for returning to the Owner all items issued during construction such as keys, security passes, site admittance badges, and all other pertinent items. The Contractor shall be responsible for notifying the appropriate utility companies to transfer utility charges from the Contractor to the Owner. The utility transfer date shall not be before Substantial Completion and may not be until Final Completion, if the Owner does not take beneficial use of the facility and the Contractor's forces continue with the Work.

#### **K.10 SURVIVAL**

All warranty and indemnification provisions of this Contract, and all of Contractor's other obligations under this Contract that are not fully performed by the time of Final Completion or termination, shall survive Final Completion or any termination of the Contract

### **SECTION L *LEGAL RELATIONS & RESPONSIBILITIES***

#### **L.1 LAWS TO BE OBSERVED**

In compliance with ORS 279C.525, Sections L.2 through L.4 contain lists of federal, state and local agencies of which the Owner has knowledge that have enacted ordinances or regulations relating to environmental pollution and the preservation of natural resources that may affect the performance of the Contract:

#### **L.2 FEDERAL AGENCIES**

Agriculture, Department of  
Forest Service  
Soil Conservation Service  
Coast Guard  
Defense, Department of  
Army Corps of Engineers  
Energy, Department of  
Federal Energy Regulatory Commission  
Environmental Protection Agency  
Health and Human Services, Department of  
Housing and Urban Development, Department of  
Solar Energy and Energy Conservation Bank  
Interior, Department of  
Bureau of Land Management  
Bureau of Indian Affairs  
Bureau of Mines

#### **EXHIBIT 1, ATTACHMENT C – GENERAL CONDITIONS**

Bureau of Reclamation  
Geological Survey  
Minerals Management Service  
U.S. Fish and Wildlife Service  
Labor, Department of  
Mine Safety and Health Administration  
Occupation Safety and Health Administration  
Transportation, Department of  
Federal Highway Administration  
Water Resources Council

### **L.3 STATE AGENCIES**

Administrative Services, Department of  
Agriculture, Department of  
Soil and Water Conservation Commission  
Columbia River Gorge Commission  
Energy, Department of  
Environmental Quality, Department of  
Fish and Wildlife, Department of  
Forestry, Department of  
Geology and Mineral Industries, Department of  
Human Resources, Department of  
Consumer and Business Services, Department of  
Land Conservation and Development Commission  
Parks and Recreation, Department of  
State Lands, Division of  
Water Resources Department of

### **EXHIBIT 1, ATTACHMENT C – GENERAL CONDITIONS**

#### **L.4 LOCAL AGENCIES**

City Councils

County Courts

County Commissioner, Board of

Design Commissions

Historical Preservation Commission

Planning Commissions



## **Exhibit 2**

### **GMP AMENDMENT TO DESIGN/BUILD CONTRACT**

**EXHIBIT 2, ATTACHMENT C – SAMPLE GMP AMENDMENT**

**GMP AMENDMENT TO DESIGN/BUILD CONTRACT**

**THIS AMENDMENT IS BETWEEN:**

**OWNER:** **The Port of Alsea, Oregon**

**And**

**DESIGN/BUILD CONTRACTOR ("the DBC"):**

**The Project is:** **Boat Launch and Marina Construction Project**

**Date of Original Design/Build Contract ("Contract"):** \_\_\_\_\_

**Date of this Amendment:**  
\_\_\_\_\_

**EXHIBIT 2, ATTACHMENT C – SAMPLE GMP AMENDMENT**

The Owner and DBC hereby amend the Contract as set forth below. Capitalized terms not otherwise used herein shall have the meanings given in the Contract. Except as amended hereby, the Contract remains in full force and effect.

**1. GMP.** The parties agree that the GMP for the Project is \$ \_\_\_\_\_, consisting of the Program Refinement and Schematic Design Fee, the Estimated Cost of the Work and the Design/Build Fee (stated as a fixed dollar lump sum amount), as follows:

**Program Refinement & Schematic Design Fee:**

**Estimated Cost of Work (Est. COW):**

**Design/Build Fee ( \_\_ % of Est. COW):** \_\_\_\_\_

**GMP (Total of above categories):**

For purposes of determining the GMP, the Estimated Cost of the Work includes the DBC's Contingency, the Fixed Cost for GC Work, and the costs of all components and systems required for a complete, fully functional facility.

**2. Basis of GMP.** The GMP is based on the GMP Supporting Documents attached as Attachments A-F ( \_\_\_\_ pages) including the Allowances, assumptions, exclusions, unit prices, and alternates designated therein.

**3. Plans and Specifications.** The Plans and Specifications for the Project are as listed in the GMP Supporting Documents. The DBC shall perform Construction Phase Services in accordance with the local and State Codes, Plans and Specifications and the other Contract Documents.

**4. Substantial Completion Date.** Notwithstanding any provision in the GMP Supporting Documents to the contrary, the required date for Substantial Completion shall be \_\_\_\_\_.

**THIS CONTRACT** is executed in four original copies of which one is to be delivered to the DBC, and the remainder to Owner

**EXHIBIT 2, ATTACHMENT C – SAMPLE GMP AMENDMENT**

**DBC:**

Name of Firm: \_\_\_\_\_

Address: \_\_\_\_\_

DBC's Federal I.D. #: \_\_\_\_\_

Construction Contractor's Board Registration No.: \_\_\_\_\_

\_\_\_\_\_  
Signature of Authorized Representative of DBC

\_\_\_\_\_  
Title

\_\_\_\_\_  
Date

**OWNER:** \_\_\_\_\_

The Port of Alsea:

\_\_\_\_\_  
Signature of Owner's Authorized Representative

\_\_\_\_\_  
Title

\_\_\_\_\_  
Date

APPROVED AS TO LEGAL SUFFICIENCY

Legal Counsel: \_\_\_\_\_

Date: \_\_\_\_\_

**EXHIBIT 2, ATTACHMENT C – SAMPLE GMP AMENDMENT**

Attachment A Plans, Specifications, Supplementary Conditions of the Contract, on which the  
Guaranteed Maximum Price is based, pages \_\_\_\_\_ through \_\_\_\_\_ dated \_\_\_\_\_

Attachment B Allowance items, pages \_\_\_\_\_ through \_\_\_\_\_ dated \_\_\_\_\_

Attachment C Assumptions and clarifications made in preparing the Guaranteed Maximum  
Price, pages \_\_\_\_\_ through \_\_\_\_\_, dated \_\_\_\_\_

Attachment D Completion schedule, pages \_\_\_\_\_ through \_\_\_\_\_, dated \_\_\_\_\_

Attachment E Alternate prices, pages \_\_\_\_\_ through \_\_\_\_\_ dated \_\_\_\_\_

Attachment F Unit prices, pages \_\_\_\_\_ through \_\_\_\_\_, dated \_\_\_\_\_

Attachment G General Conditions Costs

**EXHIBIT 2, ATTACHMENT C – SAMPLE GMP AMENDMENT**